

# MAGB1

# User Guide

## BATTERY POWERED



**Arkon Flow Systems**  
Nováčkova 11, 614 00 Brno, Czech Republic  
Tel. +420 543 214 822, Tel./Fax +420 543 215 249  
Enquiries/ Orders/ General questions: office@arkon.co.uk  
Marketing support/ Brochures: marketing@arkon.co.uk  
Technical support: support@arkon.co.uk  
[www.arkon.co.uk](http://www.arkon.co.uk)

# List of Contents

<b>1. Introduction</b>	<b>3</b>
1.1. Operating Principle	3
1.2. Applications	3
1.3. Safety Instructions	3
1.4. Unpacking the flowmeter	3
<b>2. Installation</b>	<b>4</b>
2.1. Remote or Compact?	4
2.2. Sensor installation	4
2.3. Dry liner	5
2.4. Installation of the transmitter	6
2.5. Cables connections	7
2.6. IP68 Certificate	8
<b>3. MAGB1 Transmitter Unit</b>	<b>9</b>
3.1. Main screen	9
<b>4. Battery</b>	<b>11</b>
4.1. Battery Specification	11
4.2. Battery life	11
4.3. Changing the battery	11
<b>5. Pulse output</b>	<b>12</b>
<b>6. USB communication</b>	<b>15</b>
<b>7. RS485 Module</b>	<b>16</b>
<b>8. 3G/GPRS/GSM Module</b>	<b>17</b>
<b>9. M-Bus Module</b>	<b>18</b>
<b>10. Modbus</b>	<b>19</b>
10.1. Introduction	19
10.2. Definitions and Abbreviations	19
10.3. References	19
10.4. Technical data	19
10.5. General Modbus RTU	20
10.6. Commissioning	21
10.7. Modbus addressing module	21
10.8. Modbus function codes	21
10.9. Modbus holding registers	22
10.10. Password	22
10.11. Real-time measurement	23
10.12. Info	24
10.13. Display	26
10.14. User settings	27
10.15. Factory Settings	30
10.16. Datalogger	33
<b>11. Internal backup</b>	<b>34</b>
11.1. Automatic saving data	34
11.2. Load default settings	34
<b>12. MAGB1 SW</b>	<b>35</b>
12.1. System requirements	35
12.2. Installation/Uninstall MAGB1 software	35
12.3. Service section	36
12.4. Statistic section	42
<b>13. OIML R49 certification</b>	<b>43</b>
<b>14. Liner and electrode selection</b>	<b>44</b>
<b>15. Flowmeter Dimensions</b>	<b>45</b>
<b>16. How to order your MAGB1</b>	<b>47</b>
<b>17. MAGB1 Error Code Table</b>	<b>48</b>
<b>18. Firmware version compatibility</b>	<b>49</b>

<b>19. Appendix</b> .....	<b>50</b>
19.1. CE and Conformity .....	50
19.2. Warranty.....	50
19.3. Contact .....	50

# 1. Introduction





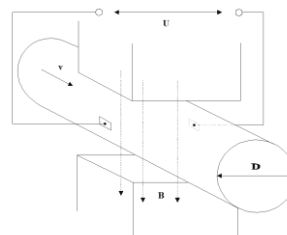

## 1.1. Operating Principle

The measurement is based on the principle of Faraday's law on electromagnetic induction in which an electric voltage is induced in an electrically conductive body that moves in a magnetic field. Liquid flows through a tube in the direction of the magnetic field. Liquid with a certain minimum electrical conductivity induces a voltage which is detected by two electrodes located in a 90 degree angle from the magnetic field and the flow direction.





Minimum liquid conductivity	>20 $\mu\text{s} / \text{cm}$ for demineralised cold water.
	>5 $\mu\text{s} / \text{cm}$ for other liquid.
Liquid velocity	min. 0.1 m / sec, max. 10 m / sec.

## 1.2. Applications

					
Water / waste water	Chemical industry	Food industry	Power engineering	Agriculture	Effluent Industry

## 1.3. Safety Instructions

	Please read this manual carefully before using the product.
	Keep this manual for future reference. Arkon Flow Systems, s.r.o. will not be liable for any damage caused by improper use of the product or its accessories.
	The MAGB1 flowmeter must not be mounted in explosive hazardous areas.

## 1.4. Unpacking the flowmeter



- ❶ While unpacking the flowmeter, conduct a visual check of the flowmeter upon receipt to make sure the product has not been damaged during transport.
- ❷ Check the completeness of the package. In case of any problem, contact the Arkon sales department without delay.
  - Flowmeter
  - Cables
  - USB Flash drive + Manual
  - Mounting kit + Key

## 2. Installation

### 2.1. Remote or Compact?

Any MAGB1 flowmeter can be delivered in two versions: Compact or Remote. The compact version has the transmitter unit connected directly to the sensor body. This version does not require any further mounting or installation of the transmitter.

The remote version has a separated transmitter. It is connected to the sensor via a cable. The cable entry into the sensor is protected by a junction box, which is potted to IP68. The cable entry on the transmitter side is through a M20x1,5 gland.



The cable type used for the connection between sensor and transmitter for remote versions: UNITRONIC® Li2YCY (PiMF), 2x2x0.34

The MAGB1 can be used with a maximum 6 mts of cable between sensor and transmitter in remote version.

### 2.2. Sensor installation

Sensor dimensions can be found on chapter 15.

Proper sensor installation is extremely important in order for your flowmeter to work correctly. Below, you will find the minimum sensor installation requirements that need to be respected at all time.

Sensor installation requirements:

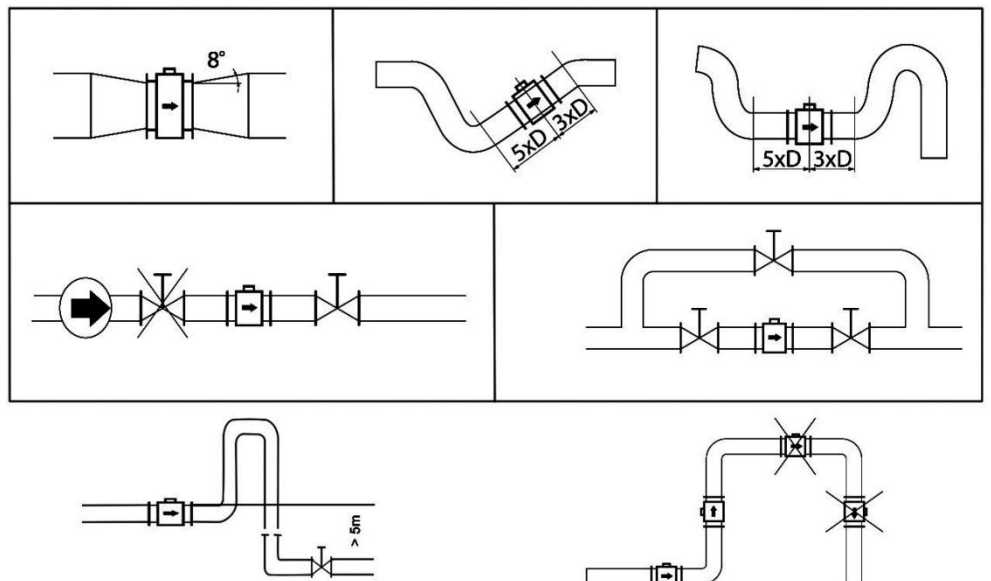

All MAGB1 sensors are supplied with a built in earthing electrodes that are sufficient for all applications with metal pipes and tanks. However on applications where all pipes and tanks are manufactured from plastic, it is recommended that earthing rings are also installed to ensure the maximum resistance of the sensor to earth is <math><1\text{ ohm}</math>.

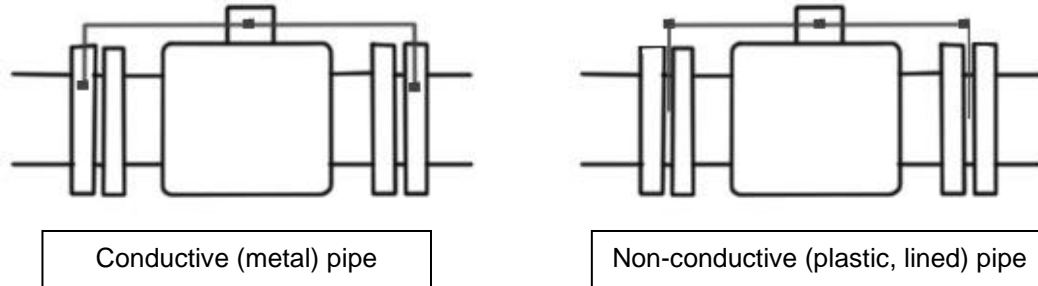

Sensor grounding with earthing rings:

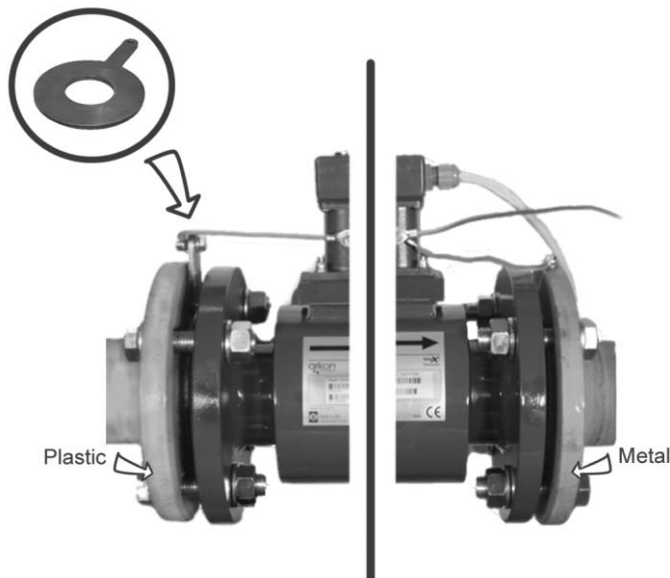

### 2.3. Dry liner

Flowmeters with a Hard Rubber liner can show incorrect readings during the first 2-3 days after installation. This is due to the fact that the time needed for transport and the time before installation is long enough for the liner to dry out and thus it changes shape/size. This change, in effect, affects reading accuracy. Simply be keeping the meter wet, this problem solve itself within 2-3 days and no other action is required at all.



## 2.4. Installation of the transmitter

	<p>The transmitter contains harmless silica gel for moisture absorbent purpose. Please do not remove from the meter.</p>
---	--

In case of a compact flowmeter version, the transmitter will need no further installation, and should be ready for use.

In case of a remote version, the following 4 steps are necessary.

- 1 Mount the transmitter to a wall, panel, or DIN-rail.

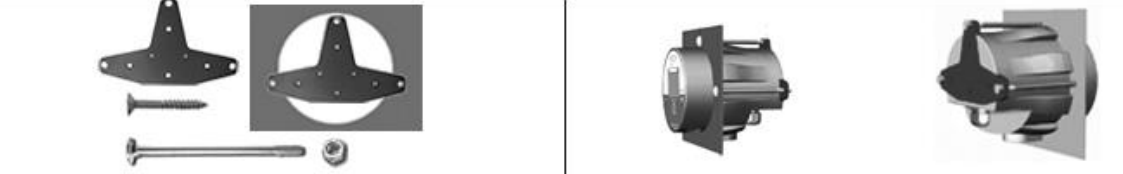
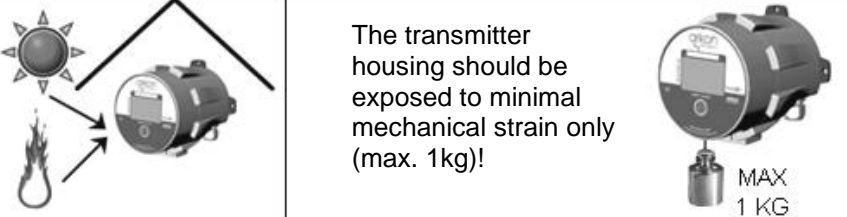
<p>Wall mounting:</p>	
<p>DIN-rail mounting:</p>	
<p>Panel mounting:</p>	
<p>The electronics have to be protected against direct sunlight and high temperatures!</p>	<p>The transmitter housing should be exposed to minimal mechanical strain only (max. 1kg)!</p> 

- 2 Connect the transmitter to the signal cable from the sensor.  
To do this undo four M6x22 screws using allen key nr.5 that is part of the delivery.

After the meter is opened, pull the signal cable through the cable gland on the bottom of the transmitter housing. Connect the connector at the end of the signal cable from the sensor to the transmitter circuit board.

	<p>Electrical installation should only be performed by a qualified person. Standard safety regulations for hazardous electrical installations have to be respected.</p> <p>The O-ring sealing shall be exchanged every 6 months of operation.</p>
---	---

④ Set up the transmitter for use.

You are now ready to start using your flowmeter or to customize its settings as per your requirements. For example;

- Set-up the measurement unit of flow-rate displayed, e.g. m3/hr.
- Set up of the unit for the volume displayed. For all volume counters this same unit will be used.

## 2.5. Cables connections

The following diagram shows the connections of the cables between sensor and transmitter.

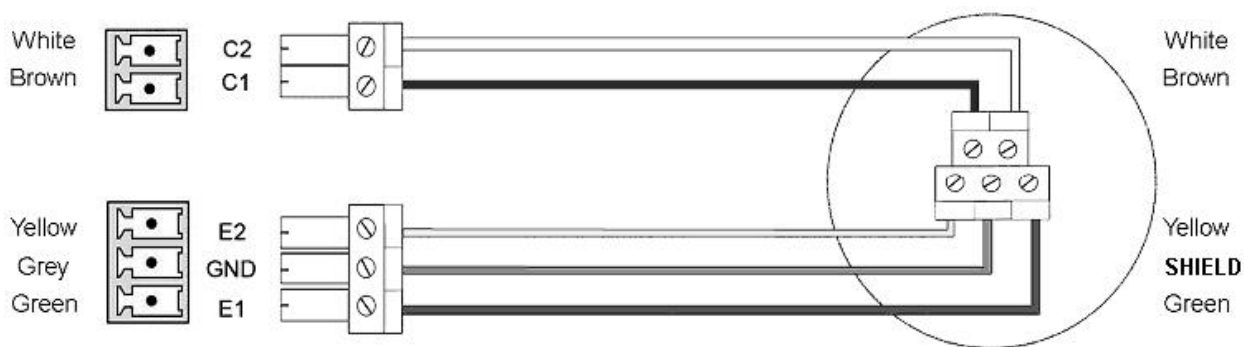

Recommended cable Li2YCY 2 x 2 x 0.34 PiMF.



## 2.6. IP68 Certificate

  
Strojírenský zkušební ústav, s.p. (Engineering Test Institute, Public Enterprise),  
Hudcova 424/56b, 621 00 Brno, Czech Republic

# CERTIFICATE

## B-32-00336-16

Manufacturer: Arkon Flow Systems, s.r.o.  
Berkova 534/92, 612 00 Brno - Královo Pole  
Czech Republic

Company ID No.: 27683826

Products: Electromagnetic flowmeters

Type designation: MAGB1

Versions: Compact, Remote

The Engineering Test Institute, Public Enterprise, hereby certifies that the characteristics of the sample of the products concerned have been found conforming to the applicable requirements

for the IP 68 protection rating as per ČSN EN 60529:1993 (at a water level of 1.25 m above the top edge of the sample for the duration of 15 hours).

This Certificate has been issued based on Final Report 32-0261 of 2016-03-23, issued by the Engineering Test Institute, Public Enterprise.

The rules for using the Certificate are specified on Page 2.

Brno, 2016-03-23



  
.....  
Ing. Tomáš Hruška  
Director

B-32-00336-16, page 1 (2)

Strojírenský zkušební ústav, s.p., Hudcova 56b, 621 00 Brno, Česká republika  
Engineering Test Institute, public enterprise, Hudcova 56b, 621 00 Brno, Czech Republic

[www.szutest.cz](http://www.szutest.cz)



### 3. MAGB1 Transmitter Unit

The MAGB1 Transmitter unit is the main part of the flowmeter. It consists of the MAGB1 motherboard, a graphical display, touch-button and transmitter housing. Through the display and with help of the button, you can see the flow and change between totalizers. The following symbols are used in this manual and on the flowmeter display.

#### 3.1. Main screen

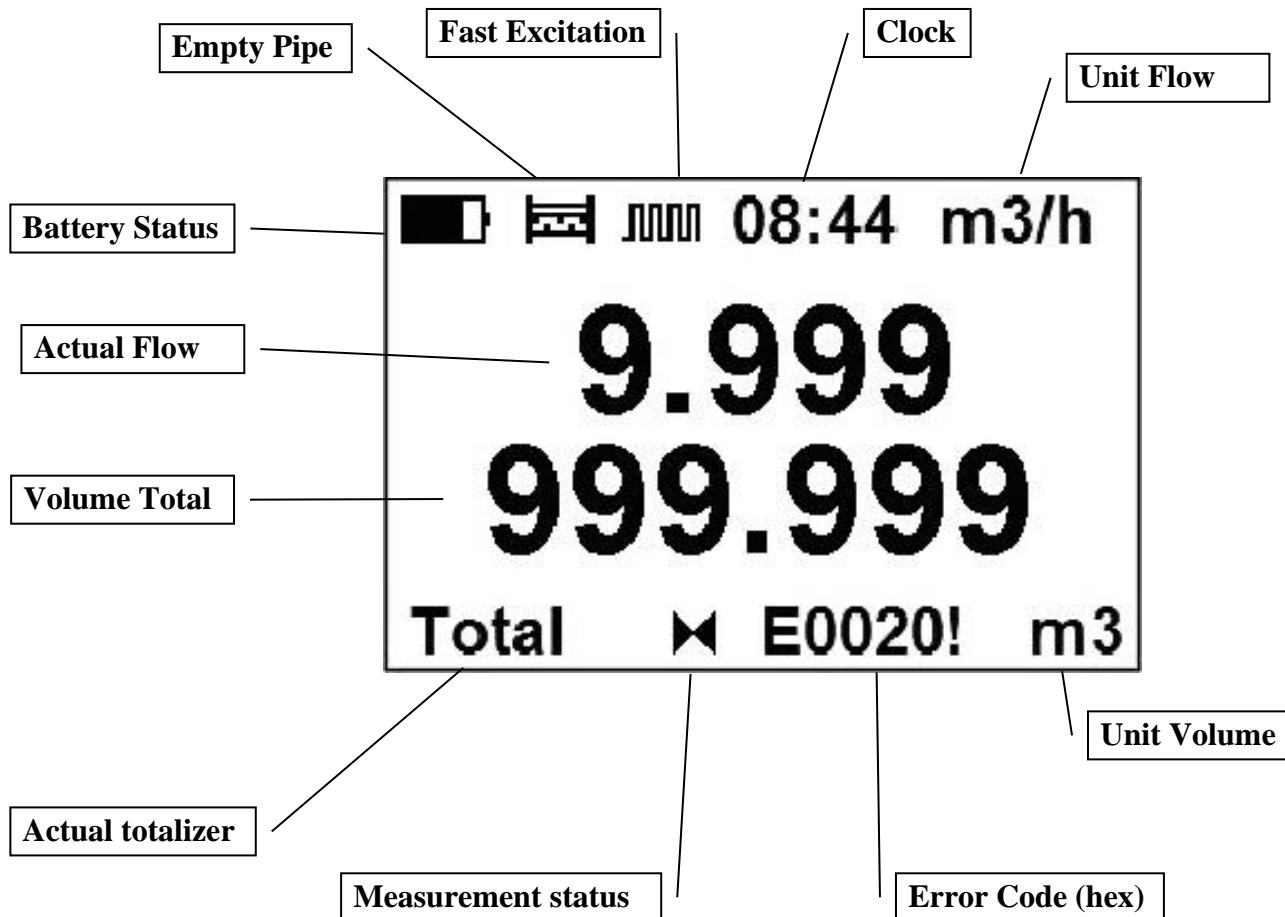

#### Total Volume

This is the total volume counter; the sum of all historical flows for a particular flowmeter. The user is not able to zero this counter without use of the factory password. Direction of flow is ignored for this counter (negative flow is calculated the same way as positive flow).

#### Total + Volume

This counter is only credited when the measured medium is flowing in the chosen positive direction. In case the flow is 0, or if it is flowing in the opposite (negative) direction, the number on the counter remains the same.





#### Total - Volume

This counter works the same way as the positive volume counter, yet in the opposite direction. In case the flow is 0, or flowing in the designated positive direction, the number on this counter will remain the same.



#### Auxiliary + Volume

This is a 2nd total + volume counter. It works the same as the Total + Volume counter, yet with the only difference being that it can be reset to 0 at any time, with User Settings password.

You can cycle through these 4 indication screens by pressing the button on the transmitter.

Symbol	Battery capacity
	100 % - 80 %
	80 % - 60 %
	60 % - 40 %
	40 % - 20 %
	< 20%

 If the battery capacity display is between 20% - 40%, we recommend that the existing batteries are replaced with new batteries.

Symbol	Measurement status
	Stop: If the display indicates this symbol, the totalizers are not incremental.
	Running: Flow meter run, totalizers are incremental

Symbol	Fast Excitation function
	This icon indicates a maximum frequency of excitation (6.25 Hz). This option is available if you turn on this function in user menu and push the button for more than 5 second. The following 5 minutes will be at Fast Excitation and will then revert back to the previous setting.

 **This setting is battery consumable!**

## 4. Battery

### 4.1. Battery Specification

	Electrical Specifications of standard 2 pack batteries	Electrical Specifications of extended 5 pack batteries
Nominal voltage	3,6V	3,6V
Capacity	38000 mAh	75000 mAh
Estimated battery life	Up to 5 years (dependent on flowmeter settings and ambient conditions)	Up to 10 years (dependent on flowmeter settings and ambient conditions)
Temp. Range	-20 – 70°C	-20 – 70°C
Dimensions:	width = 69 mm - depth = 35 mm - height = 60 mm	width = 99 mm - depth = 54 mm - height = 60 mm
Weight	200 g	430 g

**NOTE: The specifications mentioned above are related only to “Arkon battery packs”. We can only guarantee them when using original Arkon batteries. A new battery packs can be ordered from Arkon.**

### 4.2. Battery life

The battery operation time depends on ambient temperature, conditions, flowmeter functions.

Excitation frequency [Hz]	6.25	3.125	1.5625	1/5	1/15	1/30	1/60
Average battery operation time [months] of standard 2 batteries pack	2	4	8	36	48	60	60
Average battery operation time [months] of extended 5 batteries pack	4	8	16	72	96	120	120

If the USB is connected, display still on, bin setting signal chose to Volume pulse, than the battery life is short.

#### Example1:

- Excitation = 1/15
- Display Still ON
- Setting signal = Volume pulse
- USB connected

Then the standard two-pack battery life is about 11 months.

#### Example2:

- Excitation = 1/15
- Display Off
- USB disconnect

Then the standard two-pack battery life is about 63 months.

### 4.3. Changing the battery

If the battery indicator indicates low battery capacity, remove the battery by the following steps:

- ❶ Connect the new battery pack to the second connector (without losing data).
- ❷ Un-plug the old battery pack, remove it, reinstall new battery pack.
- ❸ Activate in USER menu Battery Change (see chapter 12.3)



## 5. Pulse output

As an analogue output MAGB1 has pulse output configurable to an error detection or flow dependent. The output is galvanically isolated open drain with following connection:

Connection:

### POSITIVE PULSE

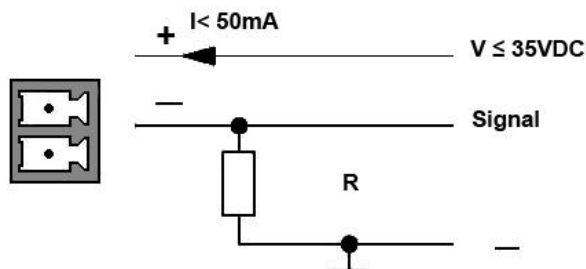

### NEGATIVE PULSE

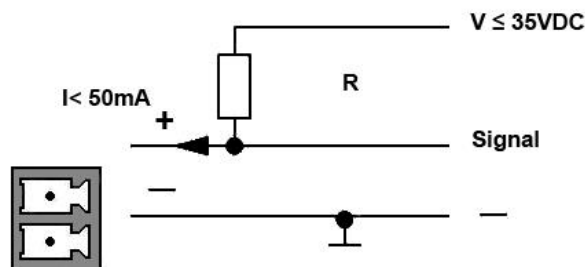

Recommended resistance  $R=1\text{ k}\Omega$

The output can be set to:

- 0) **OFF** (default)
- 1) **Flow +** output ON, for any positive flow
- 2) **Flow -** output ON, for any negative flow
- 3) **Error** output ON, for any error identified by the device
- 4) **Air Detect** output ON, during air detection (empty pipe)
- 5) **Fixed** output ON, fixed status signal
- 6) **ON In** output ON, if the actual flow is within the given range with hysteresis (can be set under Comparator Flow - Flow 1, Flow 2, Hysteresis 1 and Hysteresis)
- 7) **ON Out** output ON, if the actual flow is outside the given range with hysteresis (can be set under Comparator Flow - Flow 1, Flow 2, Hysteresis 1 and Hysteresis 2)
- 8) **ON > Flow1** output ON, if the actual flow is the bigger than the value set as Flow 1 and hysteresis (can be set under Comparator Flow – Flow 1, Hysteresis 1)
- 9) **ON < Flow1** output ON, if the actual flow is smaller than the value set as Flow 1 and hysteresis (can be set under Comparator Flow – Flow 1, Hysteresis 1)
- 10) **Volume pulse** – the output generate a pulse when the preset volume has passed the sensor (the pulse width can be set in Pulse width or Pulse width type). The battery current consumption is higher if you choose this option.



**Option 10 is battery consumable!**

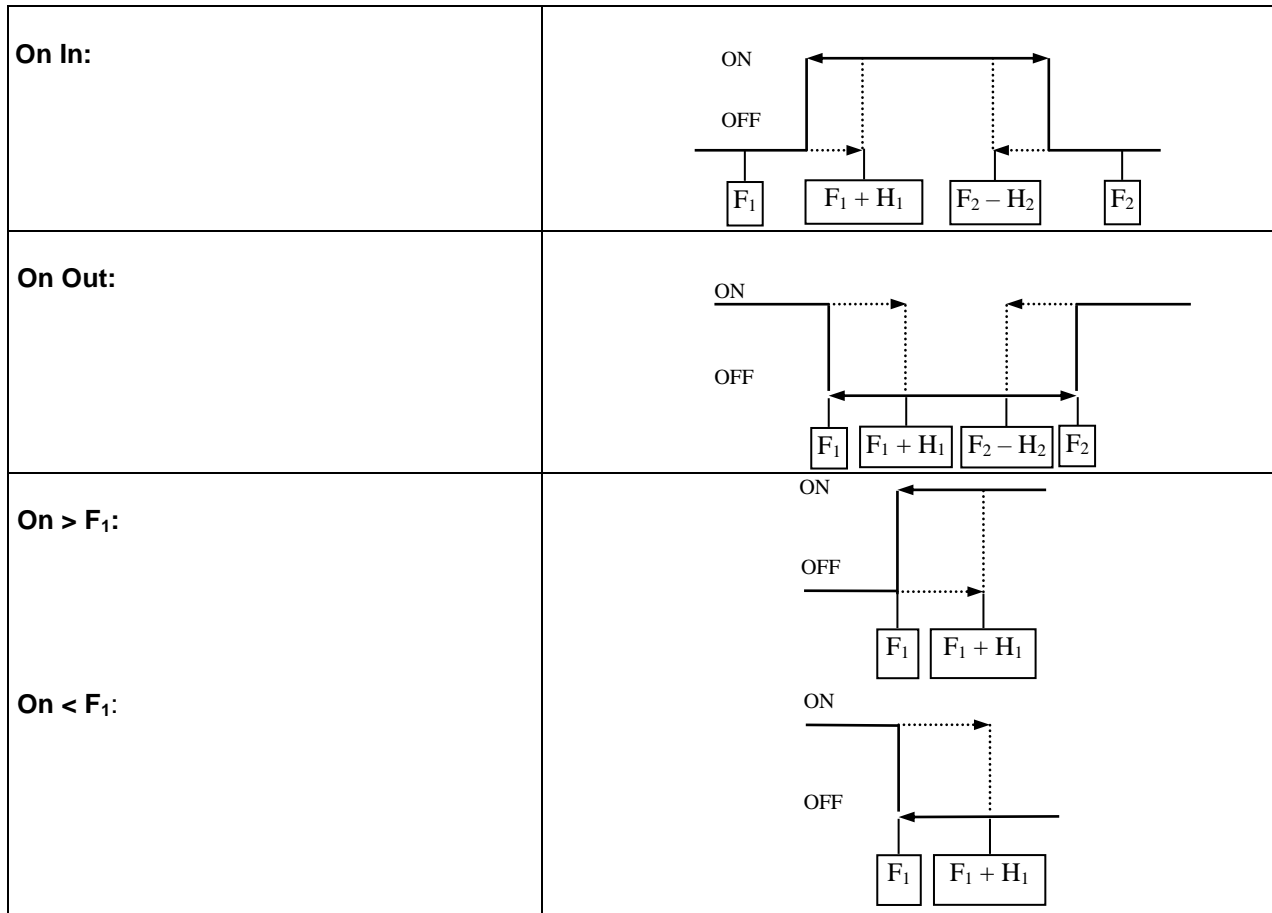

VOLUME PULSE

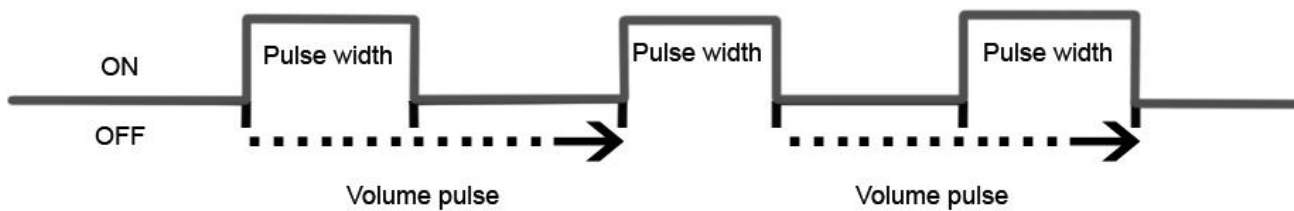

**Volume Pulse H** – volume Litres

**Volume Pulse L** – decimal fraction of the volume Litres \* 0.00000001 (to get the value multiply decimal fraction of desired volume by 100,000,000)

The number represented by Volume Pulse H and L is a number of impulses per one litre. As a standard preset from factory the output is behaving as a fast frequency output by following formula:

$$\text{Volume Pulse} = \text{Max frequency} / (\text{Max flow}[\text{m}^3/\text{hr}] / 3,6)$$

For example DN100:

Qn 80m<sup>3</sup>/hr represents 1kHz (Factory preset value)

$$\text{Volume Pulse} = 1000 / (80 / 3,6) = 45 \text{ pulses per litre}$$

Volume Pulse H = 45

Volume Pulse L = 0

If you want to set the pulses as volumetric please use following formula:

$$\text{Volume Pulse} = 1 / \text{Needed volume per one pulse in litres}$$

For example DN100:

needed output pulse for each 1000 litres passed the meters

$$\text{Volume Pulse} = 1 / 1000 = 0,001 \text{ litres per pulse}$$

Volume Pulse H = 0

Volume Pulse L = 0.00100000

All settings can be done via USB connection or RS485 communication module.

Maximum frequency pulse output depends on excitation frequency:

Excitation frequency [Hz]	Maximum frequency pulse output [Hz]
6.25	600
3.125	1000
1.625	1000
1/5	1000
1/15	1000
1/30	1000
1/60	1000

**Pulse Width** – width of the generated pulse in ms (1 – 1000 ms).

**Pulse Width Type** – Pulse Width or Duty Cycle 50%

0) **Pulse Width** (default) – the generated pulse has width set in Pulse Width

1) **Duty Cycle 50%** (default) - the generated pulse has half time to generate next pulse.

All settings can be done via USB connection or RS485 communication module.

## 6. USB communication

The only way to set and read the flowmeter is via USB interface. After connecting the standard mini USB cable to the computer you have to install drivers that you can find on USB Flash drive or websites below (except MS Windows 7). The flowmeter appears in the computer as a virtual COM port. Therefore is possible to use Arkon communication software or use your own SCADA software. The communication protocol is Modbus RTU over serial port.



**USB connect is battery consumable!**

BASIC CIRCUIT CONNECTIONS:



VIRTUAL COM PORT (VCP) DRIVERS:

<http://www.ftdichip.com/Drivers/VCP.htm>

Driver installation guide: <http://www.ftdichip.com/Documents/InstallGuides.htm>



## 7. RS485 Module

<b>Module Name:</b>	<b>Symbol:</b>	<b>Ordering Code:</b>
MAGB1 RS485 Module		*****485

### APPLICATIONS:

Industrial Automation, Industrial Process Control, Peripheral - PC and Terminal.

### Electrical Specifications

VCC to Ground	3.3 VDC	
Baud rate	Max. 19200 baud/s	

### BASIC CIRCUIT CONNECTIONS:

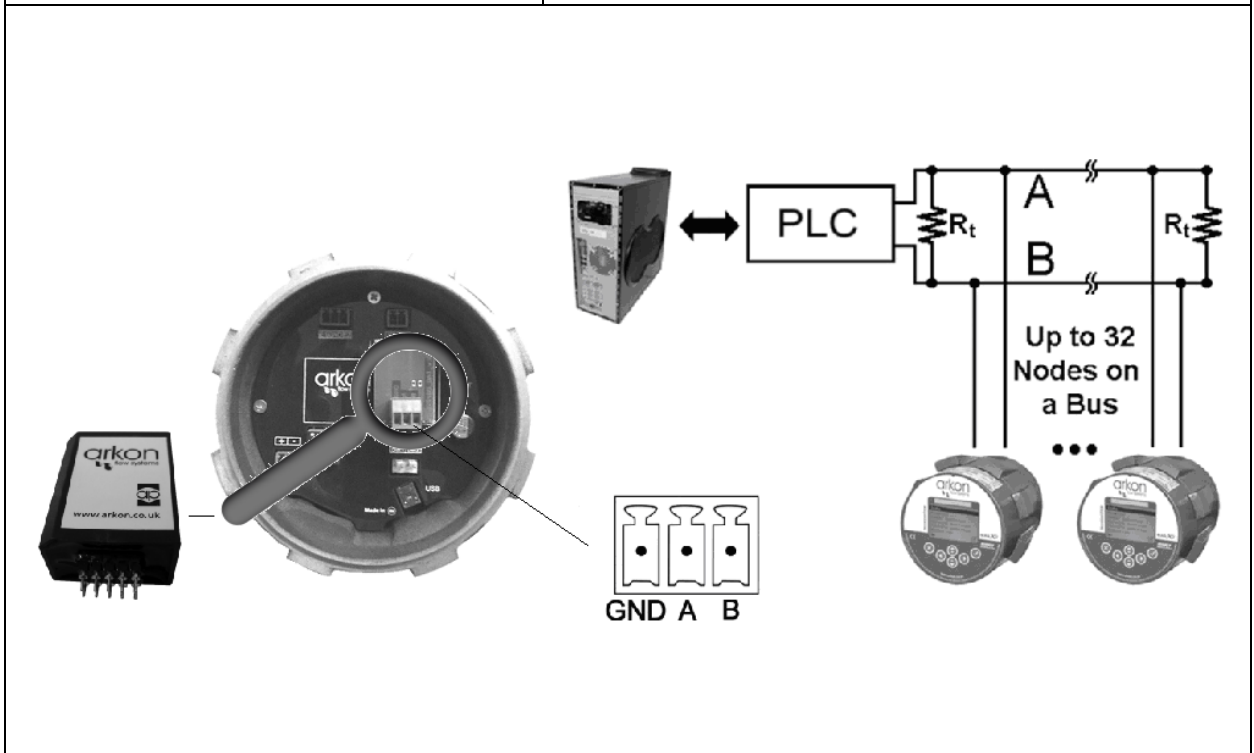

Do not use together with USB connection.

**Terminator  $R_t$  with resistance  $100\Omega$  should be connect to the end of line RS-485.**



Warning electrostatic sensitive device.



Any connection or disconnection of any module has to be done with the battery being unplugged.  
Using RS485 module affects battery life. Using extended battery pack is recommended.

## 8. 3G/GPRS/GSM Module



Module Name:	Symbol:	Ordering Code:
MAGB1 3G/GPRS/GSM Module	GPRS 	*****3G

APPLICATIONS:	
Wireless monitoring of the flowmeter via SMS messages and/or 3G/GPRS data transfer	
Electrical Specifications	
Power Sup. Current	RMS 400mA, MAX 1500mA External Li-Ion battery 4400mAh 3,6VDC
Operating systems	GSM 850 / GSM 900 DCS 1800 / PCS 1900 3G
SIM Card	3.0 / 1.8 V
Temp. Range	-20 – 70 °C

BASIC CIRCUIT CONNECTIONS:	Using the GSM-SMS Module
	

<p><b>For more information about installation and specification see document: MAGB1 3G-GPRS-GSM User Guide in the CD.</b></p> <p>The meter is sending flow and totalizer information in selected time interval to maximum 3 phone numbers in form of SMS message and/or 3G/GPRS TCP packet to selected IP address and port.</p>
---

<p><b>Warning!:</b> The only possible setting of the module is possible via setting SMS message in a setting window 15 minutes after plugin the battery. Do not use together with USB connection.</p>
---

 <p>Warning electrostatic sensitive device.</p>
 <p>Any connection or disconnection of any module has to be done with the network power to the meter switched off.</p>

## 9. M-Bus Module

<b>Module Name:</b>	<b>Symbol:</b>	<b>Ordering Code:</b>
MAGB1 Meter-Bus Module		*****MBUS

### APPLICATIONS:

Industrial Automation, Industrial Process Control

### Electrical Specifications

Baud rate	19200 baud/s	
Temp range	- 20 - 70 °C	

### BASIC CIRCUIT CONNECTIONS:

### Using the M-bus Module

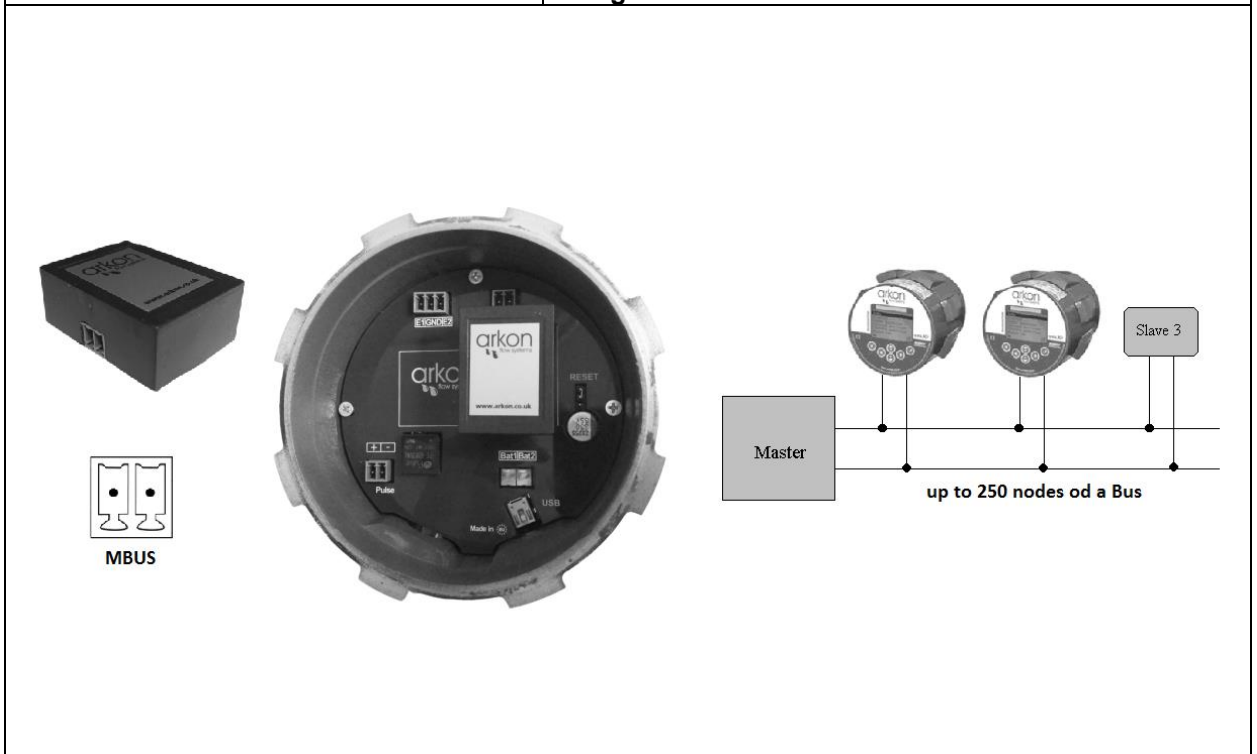

Multi-Node Network with End Termination Using module M-bus



Warning electrostatic sensitive device.



Any connection or disconnection of any module has to be done with the battery being unplugged.  
Using M-bus module affects battery life. Do not use together with USB connection.

# 10. Modbus

## 10.1. Introduction

This manual describes the MAGB1 Modbus-RTU communication protocol.

## 10.2. Definitions and Abbreviations

CRC	Cyclic Redundancy Check, Used for error-checking in Modbus RTU. See appendix
Modbus master	A Modbus device, which is able to access data in one or more connected Modbus slaves
Modbus slave	A Modbus device, which is able to respond to requests from a single Modbus master
Modbus address	Throughout this document the following notation is used to address Modbus RTU registers: 1234 - Holding register 1234 (addressed in messages by 1233)
RS 232	Refers to the communication standard defined by EIA/TIA-232C. (Physical layer) EIA/TIA232C
USB	Refers to the USB Specification usb.org
RTU	Remote Terminal Unit - Standard Modbus transmission mode

## 10.3. References

Reference 1	Modbus over Serial Line Specification & Implementation guide v. 1.0 modbus.org 12/02/02
Reference 2	Modbus Application Protocol Specification v. 1.1 modbus.org 12/06/02

## 10.4. Technical data

ARKON Flowmeter Modbus RTU specification	
Device type	Slave
Baud rates	9600, 14400, 19200, 38400, 57600, 115200 bits/sec.
Number of stations Recommended:	max. 31 per segment without repeaters
Device address range	1-247
Protocol	Modbus RTU (Other Modbus protocols like ASCII, Plus or TCP/IP are not supported)
Electrical interface	USB
Supported function code	3 read holding registers
	16 write multiple registers
	17 report slave ID
Broadcast	No
Maximum cable length	USB Specification limits
Standard Modbus over serial line v1.0)	
Certified	No

## 10.5. General Modbus RTU

The module complies with the Modbus serial line protocol [Reference 1].

Among other things, this implies a master-slave protocol at level 2 of the OSI model. One node, (the master), issues explicit commands to one of the „slave“-nodes and processes responses. Slave nodes will not transmit data without a request from the master node, and do not communicate with other slaves. Modbus is a mono master system, which means that only one master can be connected at any single point in time. Two modes of communication are possible, Unicast and Broadcast. Unicast mode is where the master sends a request to one slave device, and waits a specified time for a response. In Broadcast mode the master sends out a request to address „0“, which means that the information is for all slave devices on the network. In Broadcast mode there is no response from the slave devices.

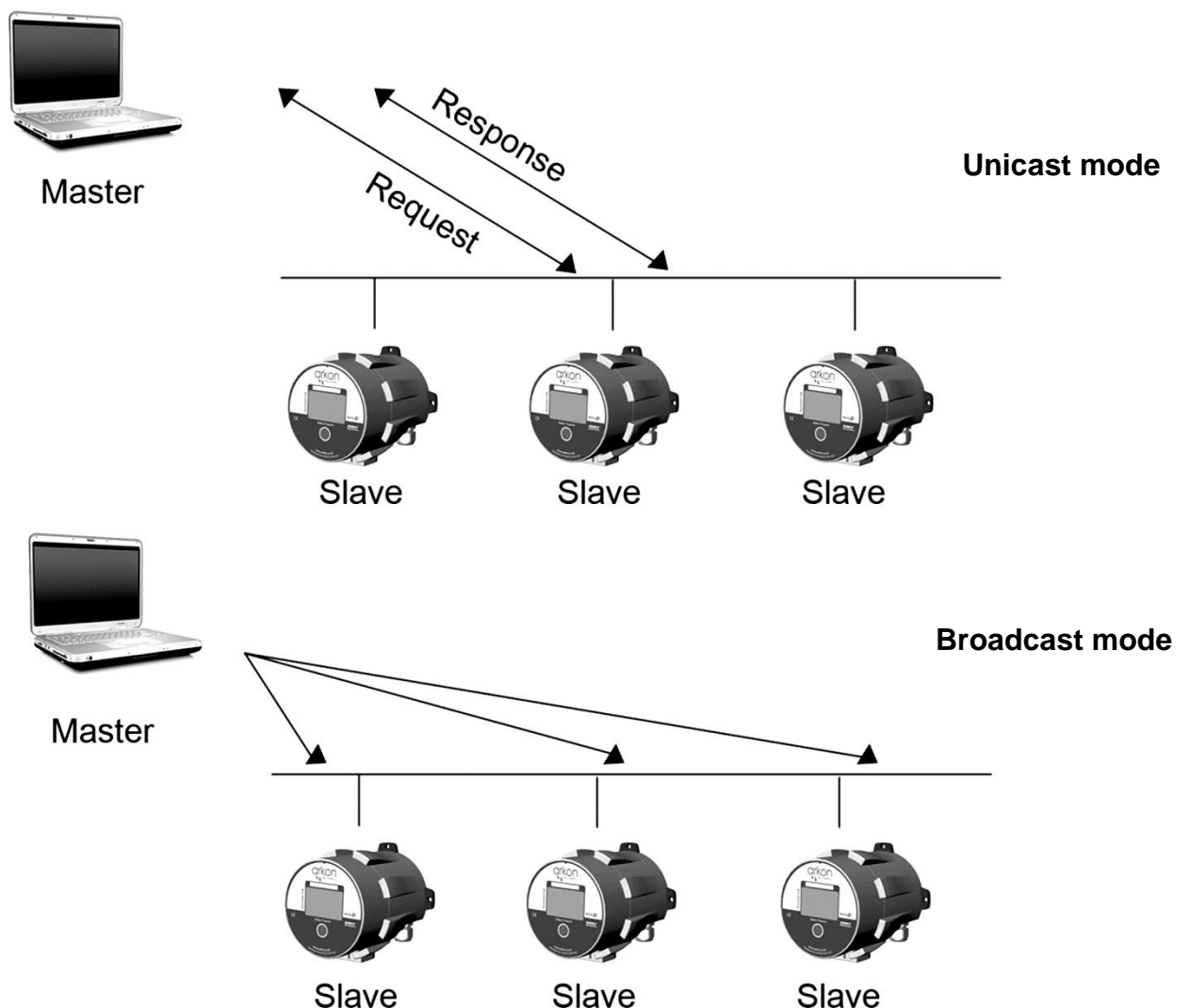

The Modbus frame is shown below, and is valid for both requests and responses.

Slave Address	Function code	Data	Crc
1 Byte	1 Byte	0-252 Bytes	2 Bytes

Further details of the Modbus protocol can be found in Reference 1 and 2.

## 10.6. Commissioning

Before communicating with the master, Baud rate, node ID and update rate must be selected.

Item	Value	Comments
Slave address	1-247	Device address [Factory setting: 1]
Baud rate	9600, 14400, 19200, 38400, 57600, 115200	Communication speed [Factory setting: 9600]
Parity/framing	Even, 1 stopbit	Communication parameters [Factory setting: None, 1 stopbit]
	Odd, 1 stopbit	
	None, 2 stopbit	
	None, 1 stopbit	

## 10.7. Modbus addressing module

The module allows R/W access to the following standard Modbus data register blocks:

- Holding registers

I.e. the module will not support the other standard data register blocks:

- Coils
- „Discrete input“
- „Input registers“

## 10.8. Modbus function codes

This device supports following function codes: 3, 16 and 17.

Function code 3 and 16 are used for accessing registers. Function code 17 (report slave ID) will return a structure of identification information of the device. Below the different function code exceptions are described.

<p><b>Function code 3</b> (Read holding registers)</p> <p>General exceptions:</p> <ul style="list-style-type: none"> <li>• Requesting less than 1 or more than 125 registers =&gt; Exception 3 (Illegal data value)</li> <li>• Requesting more than max. message size =&gt; Exception 2 (Illegal data address)</li> <li>• Requesting data above/crossing limitation of max. register address (0xFFFF) =&gt; Exception 2 (Illegal data address)</li> <li>• If the end address is only part of a mapped holding register item (e.g. one half of a longint value) =&gt; Exception 2 (Illegal data address)</li> </ul> <p>Application exceptions:</p> <ul style="list-style-type: none"> <li>• Application errors =&gt; Exception 2 (Illegal data address)</li> </ul> <p>Holes/register alignment:</p> <ul style="list-style-type: none"> <li>• The read command always returns data if no exception is given. Bad start/end alignment will result in only parts of the data item being read.</li> <li>• Holes in the holding register map return Exception 2 (Illegal data address)</li> </ul>	<p><b>Function code 16</b> (Write multiple registers)</p> <p>General exceptions:</p> <ul style="list-style-type: none"> <li>• Exceeding max. message size =&gt; Exception 2 (Illegal data address)</li> <li>• Writing data above/crossing limitation of max. register address (0xFFFF) =&gt; Exception 2 (Illegal data address)</li> </ul> <p>Application exceptions:</p> <ul style="list-style-type: none"> <li>• Application errors =&gt; Exception 2 (Illegal data address)</li> <li>• Application errors include writing to ReadOnly holding registers</li> </ul> <p>Holes / register alignment:</p> <ul style="list-style-type: none"> <li>• If start-address is not the start of a mapped holding register =&gt; Exception 2 (Illegal data address)</li> <li>• Writing to holes is not allowed =&gt; Exception 2 (Illegal data address)</li> <li>• If the end address is only part of a mapped holding register item (e.g. one half of a longint value), the action depends on the datatype.</li> <li>• If the end address is only part of a mapped holding register item (e.g. one half of a longint value) =&gt; Exception 2 (Illegal data address)</li> </ul>
<p><b>Function code 17</b> (Report Slave ID)</p> <ul style="list-style-type: none"> <li>• There are no exceptions for this function</li> </ul>	

## 10.9. Modbus holding registers

In the following the holding registers for the MAGB1 Modbus RTU module are described.

Modbus Start Register	Section
2	Password
100	Real-time measurement
1000	Info
1500	Display
2000	User settings
4000	Factory settings
10000	Datalogger

Holding registers memory map

When writing to the Holding registers, data validity is not checked. Writing incorrect values can result in unexpected behaviour of the device. In any further explanations, the following data types are used:

- **Longint** – Number consisting of 32 bits, formed by 2 Modbus registers. It is necessary to write both Low and High Word of this item, the register number always has to be an even number. Not meeting these requirements will cause an Exception 2 error (Illegal data address). In case information about the number of decimals is available, then the final number is given by the following formula:  $Y = X * 10^{(-DEC)}$ , where Y is the final number, X the read number, and DEC the number of decimals.
- **Bool** – this item can be read, but its value has no meaning. Writing value 1 to this item will cause an unspecified operation to be performed (resetting the flow totalizers, etc.) It is necessary to write both Low and High Word of this item, the register number always has to be an even number. Not meeting these requirements will cause an Exception 2 error (Illegal data address).
- **Float** – Used only for totalizers.

Data type memory map		
Modbus register	Data Type	Low/High Word
2	Longint	L
3		H
4	Bool	L
5		H
6	Float	L
7		H

## 10.10. Password

To enter the "User settings and Factory settings" sections, it is necessary to enter a password.

Modbus register	Modbus address	No. of bytes	Data type	No. of decimal	Min Value	Max Value	Description	Read/Write
2	1	4	Longint	0	0	9999	Password (User)	R*/W
4	3	4	Longint	0	0	9999	Reserved	R*/W
6	5	4	Longint	0	0	99999999	Password (Factory)	R*/W

\*) For safety purposes, it is not possible to read this item directly. In case a 0 is read from this register, it means that no valid password was entered, and the given section is not accessible. In case a 1 is read, a valid password was entered and hence the given section can be accessed freely. To close the section, you write any possible invalid password to the password entry.

## 10.11. Real-time measurement

Modbus register	Modbus address	No. of bytes	Data type	No. of decimal	Min Value	Max Value	Description	Read/Write
100	99	4	Longint	3	0	2 <sup>32</sup>	FLOW	R
102	101	4	Bool	0	0	1	SIGN	R
104	103	4	Float	N/A	0	2 <sup>32</sup>	TOTAL	R
106	105	4	Float	N/A	0	2 <sup>32</sup>	TOTAL +	R
108	107	4	Float	N/A	0	2 <sup>32</sup>	TOTAL -	R
110	109	4	Float	N/A	0	2 <sup>32</sup>	AUX +	R
112	111	4	Longint	0	0	2 <sup>16</sup>	ERROR CODE	R

### FLOW

Unit: m<sup>3</sup>/h - it is not possible to change it.  
Real value = Actual value / 1000.

### SIGN

Sign of the read flow.  
0 – positive flow  
1 – negative flow

### TOTAL (TOTAL +, TOTAL -, AUX +)

Unit: m<sup>3</sup> – it is not possible to change it.  
Real value = Actual value / 1000.

### ERROR CODE

Convert read value to binary number. Number one means error. For more information see chapter 17.

0b0000000000000000

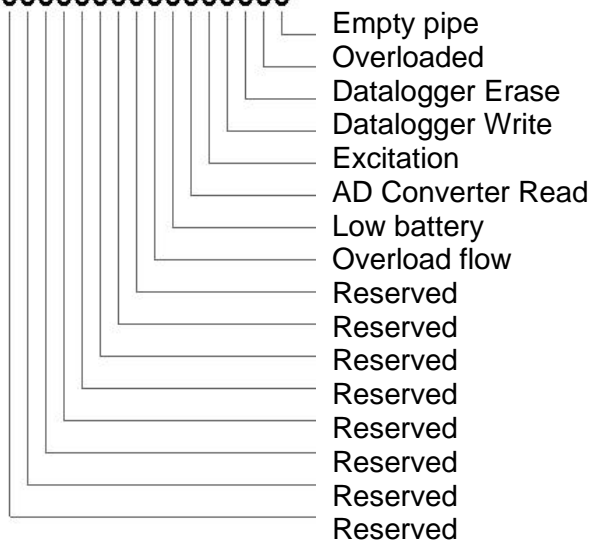



## 10.12. Info

Modbus register	Modbus address	No. of bytes	Data type	No. of decimal	Min Value	Max Value	Description	Read/Write
1000	999	4	Longint	0	0	0x00235959	Time	R
1002	1001	4	Longint	0	0	0x29991231	Date	R
1004	1003	4	Longint	0	0	999 999	Unit No.	R
1006	1005	4	Longint	0	0	2 <sup>32</sup>	Error (min)	R
1008	1007	4	Longint	0	0	2 <sup>32</sup>	OK (min)	R
1010	1009	4	Longint	0	0	1 000	Diameter	R
1012	1011	4	Longint	2	0	9 999	FirmWare No.	R
1014	1013	4	Longint	3	0	36 000 000	Flow Qn	R
1016	1015	4	Longint	0	0	2 <sup>32</sup>	Excitation counter	R
1018	1017	4	Longint	0	0	100	Battery status	R
1020	1019	4	Longint	0	0	65535	Error 1	R
1022	1021	4	Longint	0	0	0x12315959	Start 1	R
1024	1023	4	Longint	0	0	0x12315959	Stop 1	R
1026	1025	4	Longint	0	0	65535	Error 2	R
1028	1027	4	Longint	0	0	0x12315959	Start 2	R
1030	1029	4	Longint	0	0	0x12315959	Stop 2	R
1032	1031	4	Longint	0	0	65535	Error 3	R
1034	1033	4	Longint	0	0	0x12315959	Start 3	R
1036	1035	4	Longint	0	0	0x12315959	Stop 3	R
1038	1037	4	Longint	0	0	65535	Error 4	R
1040	1039	4	Longint	0	0	0x12315959	Start 4	R
1042	1041	4	Longint	0	0	0x12315959	Stop 4	R
1044	1043	4	Longint	0	0	65535	Error 5	R
1046	1045	4	Longint	0	0	0x12315959	Start 5	R
1048	1047	4	Longint	0	0	0x12315959	Stop 5	R
1050	1049	4	Longint	0	0	65535	Error 6	R
1052	1051	4	Longint	0	0	0x12315959	Start 6	R
1054	1053	4	Longint	0	0	0x12315959	Stop 6	R
1056	1055	4	Longint	0	0	65535	Error 7	R
1058	1057	4	Longint	0	0	0x12315959	Start 7	R
1060	1059	4	Longint	0	0	0x12315959	Stop 7	R
1062	1061	4	Longint	0	0	65535	Error 8	R
1064	1063	4	Longint	0	0	0x12315959	Start 8	R
1066	1065	4	Longint	0	0	0x12315959	Stop 8	R
1068	1067	4	Longint	0	0	65535	Error 9	R
1070	1069	4	Longint	0	0	0x12315959	Start 9	R
1072	1071	4	Longint	0	0	0x12315959	Stop 9	R
1074	1073	4	Longint	0	0	65535	Error 10	R
1076	1075	4	Longint	0	0	0x12315959	Start 10	R
1078	1077	4	Longint	0	0	0x12315959	Stop 10	R
1080	1079	4	Longint	0	0	65535	FW Checksum	R

**Time** - time is stored in BCD format HHMMSS (ie 08:33:15 = 0x00083315)

**Date** - date is stored in BCD format YYYYMMDD (ie 25.03.2010 = 0x20100325)

**Unit no.** – exclusive number for this Flowmeter. If there are any problems, please refer to this number.

**Error (min)** – the number of minutes the device was not measuring because of errors.

**OK (min)** - the number of minutes that the device measured correctly.

**Diameter** – this item shows the nominal sensor diameter that is currently configured for the given flowmeter.

**Firmware No.** – this shows the current firmware version

**Flow Qn** – size of Flow meter (DN or ANSI)

**Excitation Counter** – the number of excitations after battery exchange

**Battery Status** - this number shows remaining capacity of battery in %

**Error 1** – the error code number in binary format. If you need error logging you have to turn on the Error Logger in User menu.

**Start 1** – when the error occur. BCD format MMDDHHMM (ie 25.10. 13:25 = 0x25101325)

**Stop 1** – when the error ended. BCD format is the same as start.

**FW Checksum** - validation of not allowed changes in FW (metrological purposes)

## 10.13. Display

Modbus register	Modbus address	No. of bytes	Data type	No. of decimal	Min. Value	Max. Value	Default	Description	Read/Write
1500	1499	4	Longint	-	0	4	2	Unit Flow (+/-), 0=UKG/min, 1=USG/min, 2=m3/h, 3=l/min, 4=l/s	R/W
1502	1501	4	Longint	-	0	3	2	Unit Volume, 0=UKG, 1=USG, 2=m3, 3=l	R/W
1504	1503	4	Longint	-	0	100	50	Contrast [%]	R/W
1506	1505	4	Longint	-	0	2147480	30	Display Enable Time [s]	R/W

**Unit Flow** – actual flow unit (default m<sup>3</sup>/h)

**Unit Volume** – totalizer unit (default m<sup>3</sup>)

**Contrast** – Set display's contrast

**Display Enable Time** – number of seconds when the display is working after touching the button. This function is for battery conservation. Value must be multiple of 5s. (If you write bad value, non multiple, this value is automatically converted). If the value is "0", function is off and display is all the time **ON**.

## 10.14. User settings

To enter this section, it is necessary to enter the User Password "1111".

Modbus register	Modbus address	No. of bytes	Data type	No. of decimal	Min Value	Max Value	Default	Description	Read/Write
2000	1999	4	Bool	0	0	1	0	Error Logger, 0=OFF, 1=ON	R/W
2002	2001	4	Longint	0	0	9	12	Datalogger Interval, 0=OFF, 1=5min, 2=10min, 3=15min, 4=30min, 5=60min, 6=2hod, 7=6hod, 8=12hod. 9=24hod	R/W
2004	2003	4	Bool	0	0	1	0	Datalogger Delete, 0=OFF, 1=ON	R/W
2006	2005	4	Bool	0	0	1	1	Air Detector, 0=OFF, 1=ON	R/W
2008	2007	4	Bool	0	0	1	0	Delete Aux + Volume	R/W
2010	2009	4	Bool	0	0	1	0	Battery change, 0=no action, 1=change battery	R/W
2012	2011	4	Longint	0	1	30	3	Samples per Avg.	R/W
2014	2013	4	Longint	3	0	36 000 000	0	Comparator Flow 1	R/W
2016	2015	4	Longint	3	0	36 000 000	0	Comparator Flow 2	R/W
2018	2017	4	Longint	3	0	36 000 000	0	Comparator Hysteresis 1	R/W
2020	2019	4	Longint	3	0	36 000 000	0	Comparator Hysteresis 2	R/W
2022	2021	4	Longint	0	0	999 999 999	0	Volume Pulse H	R/W
2024	2023	4	Longint	8	0	99 999 999	0	Volume Pulse L	R/W
2026	2025	4	Longint	0	5	1 000	5	Pulse Width	R/W
2028	2027	4	Bool	0	0	1	1	Pulse Width Type, 0=Pulse Width, 1=Duty Cycle 50%	R/W
2030	2029	4	Longint	0	0	10	0	Binary Output - Setting - Signal, 0=OFF, 1=Flow+, 2=Flow-, 3=Error, 4=Air detect, 5=Fixed, 6=On In, 7=On Out, 8=On > F1, 9=On < F1, 10=Volume Pulse	R/W
2032	2031	4	Longint	0	1	247	1	Modbus Slave Address	R/W

2034	2033	4	Longint	0	0	5	0	Modbus BaudRate, 0=9600, 1=14400, 2=19200, 3=38400, 4=57600, 5=115200	R/W
2036	2035	4	Longint	0	0	3	3	Modbus Parity, 0=Even, 1 stopbit, 1=Odd, 1 stopbit, 2=None, 2 stopbits, 3=None, 1 stopbit	R/W
2038	2037	4	Longint	0	0	1	0	Fast Excitation Button 0= OFF, 1= ON	
2040	2039	4	Longint	0	0	1	0	Battery Pack 0= 2 pack, 1= 5 pack	

**Error Logger** - this item allows logging actual error to Info menu. Default OFF.

**Datalogger Interval** – this function selects how often data is written to the datalogger.

**Datalogger Delete** – erase all record in datalogger (recommended use after first start).

**Air Detector** – this option allows selecting empty pipe check. Default ON. If the Air detector is active and the pipe is empty, the unit automatically turns down the excitation to prolong battery life.

**Delete Aux + Volume** – write value different to zero for erasing the auxiliary flow totalizer.

**Battery change** – set to “1” when battery has been exchanged

**Samples per Avg.** – the number of samples that the flowmeter will use for calculation of its displayed average flow value. Default 3.

**Comparator Flow 1** - see chapter Pulse Output.

**Comparator Flow 2** - see chapter Pulse Output.

**Comparator Hysteresis 1** - see chapter Pulse Output.

**Comparator Hysteresis 2** - see chapter Pulse Output.

**Volume Pulse H** - see chapter Pulse Output.

**Volume Pulse L** - see chapter Pulse Output.

**Pulse Width** - see chapter Pulse Output.

**Pulse Width Type** - see chapter Pulse Output.

**Binary Output – setting signal** - see chapter 5.

**Modbus Slave Address** – Modbus device address. Default 1

**Modbus Baudrate** – setup communication speed. Default 9600.

**Modbus Parity** – setup communication parameters. Default none, 1 stopbit.

**Fast Excitation Button** – If push button longer as 5 seconds and this options is 1, activated Excitation frequency 6,25Hz. To 5 minutes will the Excitation frequency that was before push the button.

**Battery pack** – selection of connected battery pack – used when exchanging battery for correct battery life calculation.

## 10.15. Factory Settings

To enter this section, it is necessary to enter the Service Password.

Modbus register	Modbus address	No. of bytes	Data type	No. of decimal	Min Value	Max Value	Default	Description	Read/Write
4000	3999	4	Bool	0	0	1	0	Delete Total	R/W
4002	4001	4	Bool	0	0	1	0	Delete Total -	R/W
4004	4003	4	Bool	0	0	1	0	Delete Total +	R/W
4006	4005	4	Bool	0	0	1	0	Delete OK (min)	R/W
4008	4007	4	Bool	0	0	1	0	Delete Error (min)	R/W
4010	4009	4	Bool	0	0	1	0	Flow Simulation, 0=OFF, 1=ON	R/W
4012	4011	4	Longint	3	0	36 000 000	3600	Simulated Flow	R/W
4014	4013	4	Longint	0	0	1 000	-	Diameter	R/W
4016	4015	4	Longint	0	0	999999	-	Unit No.	R/W
4018	4017	4	Longint	3	0	36 000 000	-	Flow Qn	R/W
4020	4019	4	Longint	3	0	36 000 000	-	Calibration Point 1	R/W
4022	4021	4	Longint	3	0	36 000 000	-	Calibration Point 2	R/W
4024	4023	4	Longint	3	0	36 000 000	-	Calibration Point 3	R/W
4026	4025	4	Longint	0	-8388608	8388607	-	Calibration Data 1	R/W
4028	4027	4	Longint	0	-8388608	8388607	-	Calibration Data 2	R/W
4030	4029	4	Longint	0	-8388608	8388607	-	Calibration Data 3	R/W
4032	4031	4	Bool	-	0	1	0	Zero Flow Set	R/W
4034	4033	4	Bool	-	0	1	0	Zero Flow Erase	R/W
4036	4035	4	Longint	7	0	1000000	0	Zero Flow Constant	R/W
4038	4037	4	Longint	-	0	6	2	Excitation frequency, 0=1/60 Hz, 1=1/30 Hz, 2=1/15 Hz, 3=1/5 Hz, 4=1.5625 Hz, 5=3.125 Hz, 6=6.25 Hz	R/W
4040	4039	4	Bool	-	0	1	1	Excitation, 0=OFF, 1=ON	R/W
4042	4041	4	Bool	-	0	1	0	Service Mode, 0=OFF, 1=ON	R/W
4044	4043	4	Bool	-	0	1	0	Reset system	R/W
4046	4045	4	Bool	0	0	1	0	Measurement, 0=Stop,	R/W

								1=Running	
4048	4047	4	Longint	3	0	999	188	Air Constant	R/W
4050	4049	4	Bool	0	0	1	0	Invert Flow, 0=No-invert, 1=Invert	R/W
4052	4051	4	Longint	0	0	5	3	Low Flow Cutoff, 0=OFF, 1=0.5%, 2=1%, 3=2%, 4=5%, 5=10%	R/W
4054	4053	4	Longint	0	0	0x29991231	-	Date Settings	R/W
4056	4055	4	Longint	0	0	0x00235959	-	Time Settings	R/W
4058	4057	4	Longint	0	1	200	10	Excitation Delay	R/W

**Delete Total Volume** – write value different to zero for erasing the Total flow totalizer.

**Delete Total – Volume** – write value different to zero for erasing the Total – flow totalizer.

**Delete Total + Volume** – write value different to zero for erasing the Total + flow totalizer.

**Delete OK (min)** – write value different to zero for erasing the OK min counter.

**Delete Error (min)** – write value different to zero for erasing the Error min counter.

**Flow Simulation** – switch off/on the simulation flow function. Default OFF.

**Simulated Flow** – write simulated flow.

**Diameter** – diameter of the sensor.

**Unit No.** – the serial number of unit.

**Flow Qn** – setup to the excepted flow Qn. It is set automatically when you write diameter.

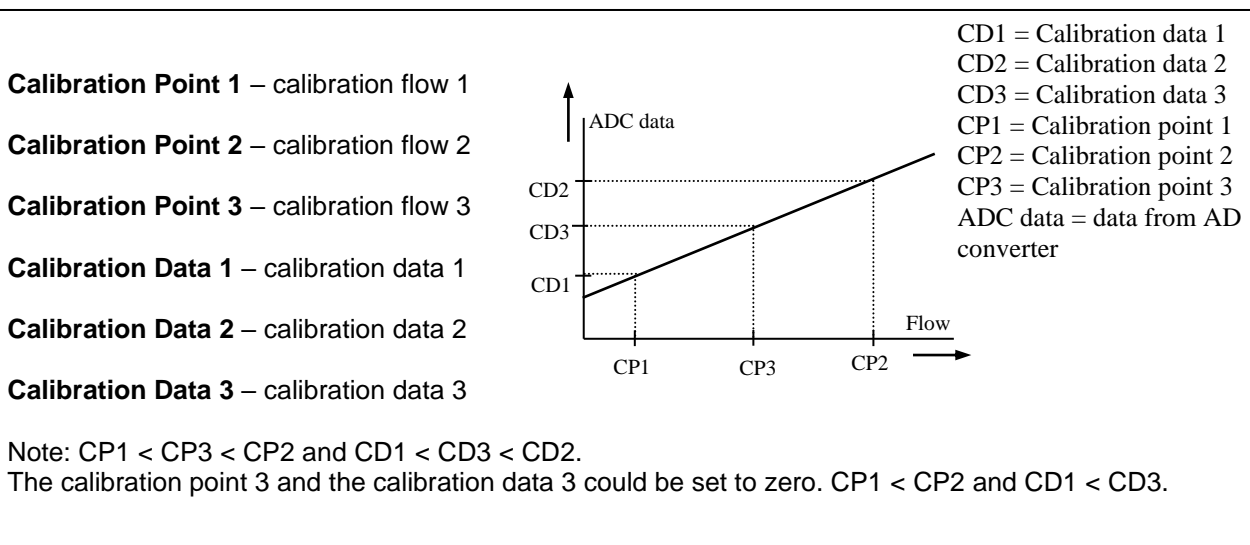

**Zero Flow Set** – after activation this function, next 125 samples are compute to average value for zero flow constant.



**Zero Flow Erase** – erase zero flow constant to 0.

**Zero Flow Constant** – Set manually value for zero flow constant.

**Excitation Frequency** – choose the excitation frequency. The battery life depends on excitation frequency.

**Excitation** – write zero for turn OFF the excitation. Default ON.

**Service Mode** – write value different to zero for turn ON the service mode. Default OFF.

**Reset** – Reset all system. After application it must be restarted by connecting MAGB1 SW with flowmeter.

**Measurement** – 0 = Stop – the unit shows actual flow, but the totalizers are stopped.  
1 = Running – totalizers are active. Default Stop.

**Air Constant** – constant value to determine the Empty pipe detection limit. Default 188.

**Invert Flow** – this function serves to change the direction of the flow. Default OFF.

**Low Flow Cutoff** – this function serves to set the minimum flow the flowmeter will react on. Default 2%.

**Date Settings** - date write in BCD format YYYYMMDD (ie 25.03.2010 = (hex)0x20100325)

**Time Settings** - time write in BCD format HHMMSS (ie 08:33:15 = (hex)0x00083315)

**Excitation Delay** - sets length of excitation period (used for sizes DN200-DN300)

## 10.16. Datalogger

Data from datalogger save into external EEPROM. Size is 32768B, capacity for write entries is 1820 (one entry has 18B)

Datalogger item	Modbus register	Modbus address	No. of bytes	Data type	No. of decimal	Min Value	Max Value	Description	Read/ Write
1.	10000	9999	4	Longint	3	0	4294967295	Total +	R
	10002	10001	4	Longint	3	0	4294967295	Total -	R
	10004	10003	2	Int	0	0	65535	Error Code	R
	10005	10004	4	Longint	0	0	0x29991231	Date	R
	10007	10006	4	Longint	0	0	0x00235959	Time	R
2.	10009	10008	4	Longint	3	0	4294967295	Total +	R
	10011	10010	4	Longint	3	0	4294967295	Total -	R
	10013	10012	2	Int	0	0	65535	Error Code	R
	10014	10013	4	Longint	0	0	0x29991231	Date	R
	10016	10015	4	Longint	0	0	0x00235959	Time	R
3.	10018	10017	4	Longint	3	0	4294967295	Total +	R
	10020	10019	4	Longint	3	0	4294967295	Total -	R
	10022	10021	2	Int	0	0	65535	Error Code	R
	10023	10022	4	Longint	0	0	0x29991231	Date	R
	10025	10024	4	Longint	0	0	0x00235959	Time	R
	...	...	...	...	...	...	...	...	...
	...	...	...	...	...	...	...	...	...
	...	...	...	...	...	...	...	...	...
1819.	26362	26361	4	Longint	3	0	4294967295	Total +	R
	26364	26363	4	Longint	3	0	4294967295	Total -	R
	26366	36365	2	Int	0	0	65535	Error Code	R
	26367	36366	4	Longint	0	0	0x29991231	Date	R
	26369	26368	4	Longint	0	0	0x00235959	Time	R
1820.	26371	26370	4	Longint	3	0	4294967295	Total +	R
	26373	26372	4	Longint	3	0	4294967295	Total -	R
	26375	26374	2	Int	0	0	65535	Error Code	R
	26376	26375	4	Longint	0	0	0x29991231	Date	R
	26378	26377	4	Longint	0	0	0x00235959	Time	R

All items in Datalogger are creating from 18 Bytes:

Total +	Total -	Err. Code	Date	Time
4B	4B	2B	4B	4B

- Total + (Total -) – Number is without decimal point. For real value must divide Actual value by 1000. Example: Actual value 26530 » 26530/1000 = 26,530 m3.
- Error Code – this number in binary form show, which errors are detected (See chapter 17)
- Date – Number in Hex form show date in format: YYYYMMDD (ex. 17.02.2010=(hex)0x20100217)
- Time – Number in Hex form show time in format: 00HH:MM:SS (ex 18:26:41=(hex)0x0018)

# 11. Internal backup

## 11.1. Automatic saving data

Once an hour some data is saved to internal EEPROM. These are:

- Time
- Date
- Total
- Total +
- Total –
- Aux +
- OK (min)
- Error (min)
- Excitation counter
- Datalogger address
- Battery status

If you don't change the battery before it is completely inactive (discharged) then only the last bit of data recovered before the battery was inactive, will be kept in the memory.

## 11.2. Load default settings

This function will load default factory settings. The proper way to do this is described below:

1. Unplug the battery
2. Jumper should be in its original position (picture 1)
3. Remove the jumper (picture 2)
4. Connect the jumper as per picture 3
5. Plug the battery back in.
6. The message "Unplug the jumper!" will appear on the display. Default settings have been loaded.
7. Now you must remove the jumper again and connect it in the original position.

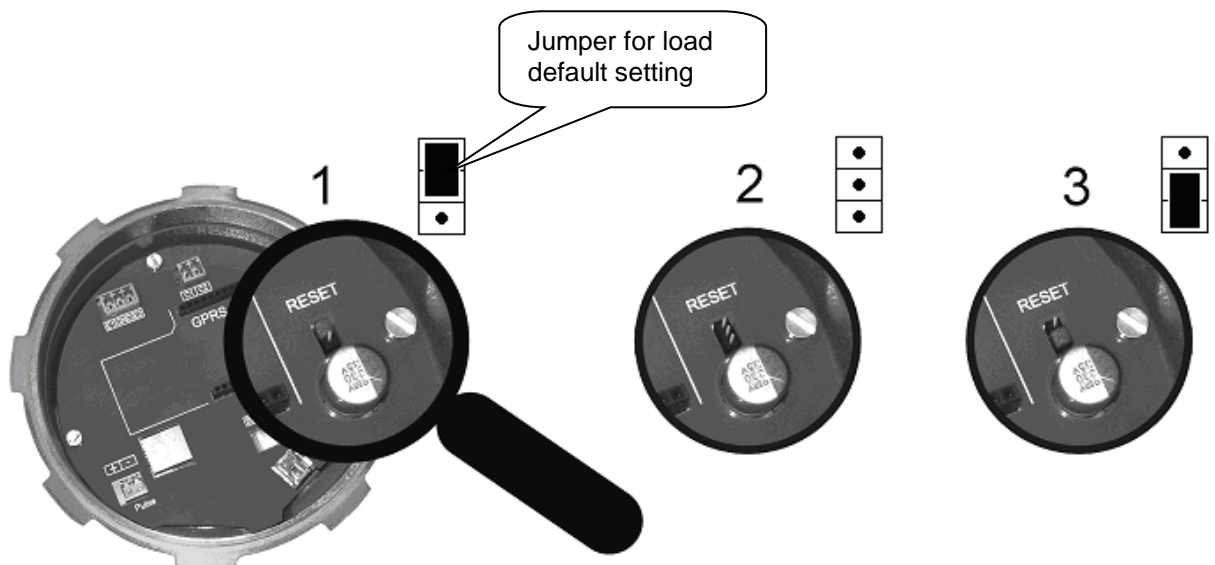

## 12. MAGB1 SW

### 12.1. System requirements

There are minimum hardware and software requirements of your computer that must be satisfied to ensure that the software functions properly. These are:

Pentium 166 MHz or better

SVGA monitor

32 MB RAM.

MS Windows 98/ME/NT/2000/XP/Vista/Windows 7 operating system.

MAGB1 software program

USBmini cable

### 12.2. Installation/Uninstall MAGB1 software

If you received the MAGB1 SW on a CD, place the CD-ROM with the MAGB1 software in your CD drive. Double-click on the CD-ROM symbol in the "My Computer" folder on the Windows desktop. Then run the "Setup.exe" in the "MAGB1 Software" folder. The installation package can be downloaded from Arkon website.

To uninstall MAGB1 SW in „Settings“ (Start menu), under „Add/remove programs“ you select MAGB1 and then click the „uninstall“ button.

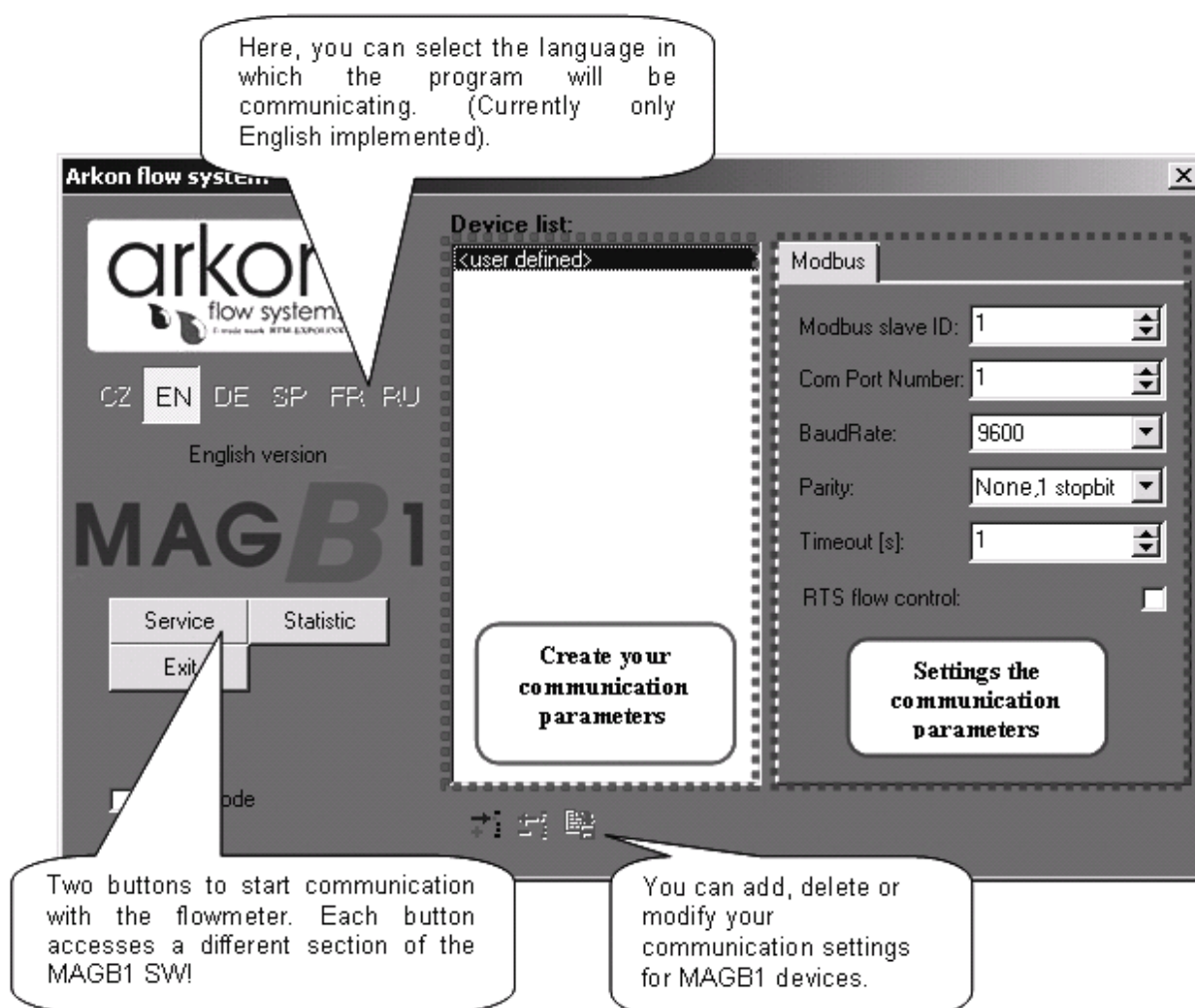

The MAGB1 software program consists of two independent sections:

- **The SERVICE section (“Service”)** – This section serves for overall remote configuration of the flowmeter. You enter this section by clicking "Service" in the above window.
- **The STATISTIC data-reading section (“Statistic”)** – This section serves for reading/exporting statistical data for given time periods from the flowmeter. You can enter this section by clicking “Statistic” in the above window.

### 12.3. Service section

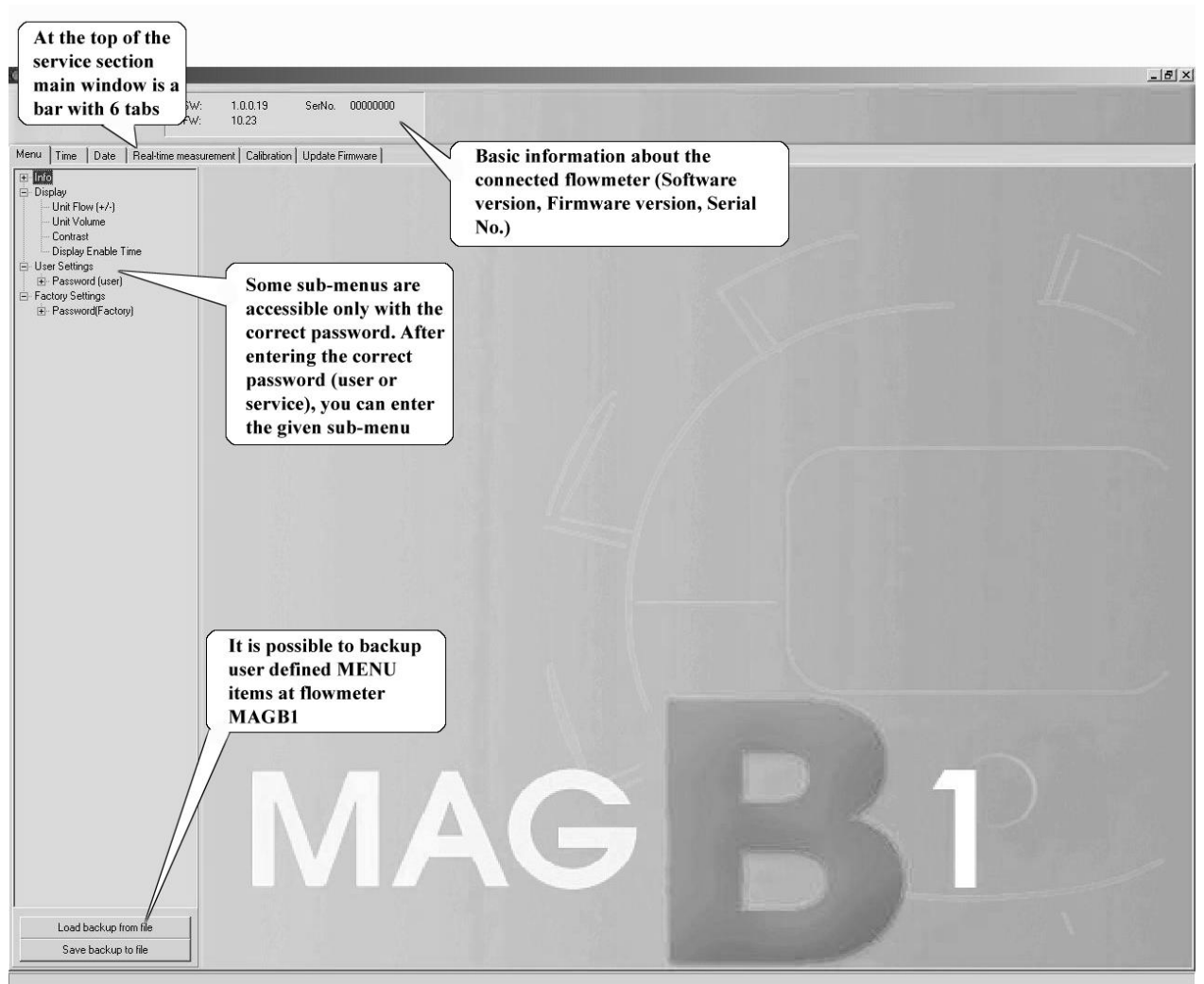

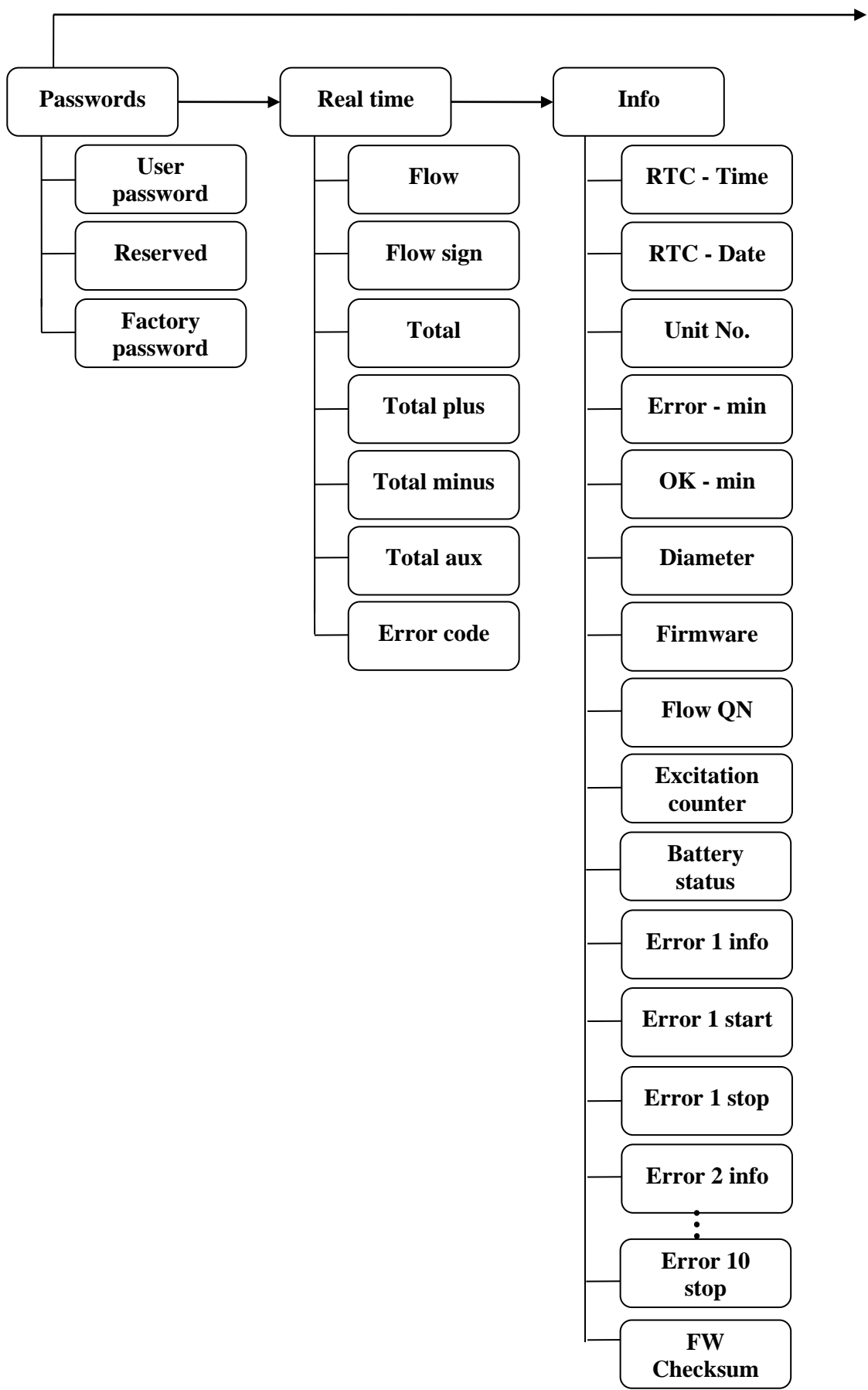

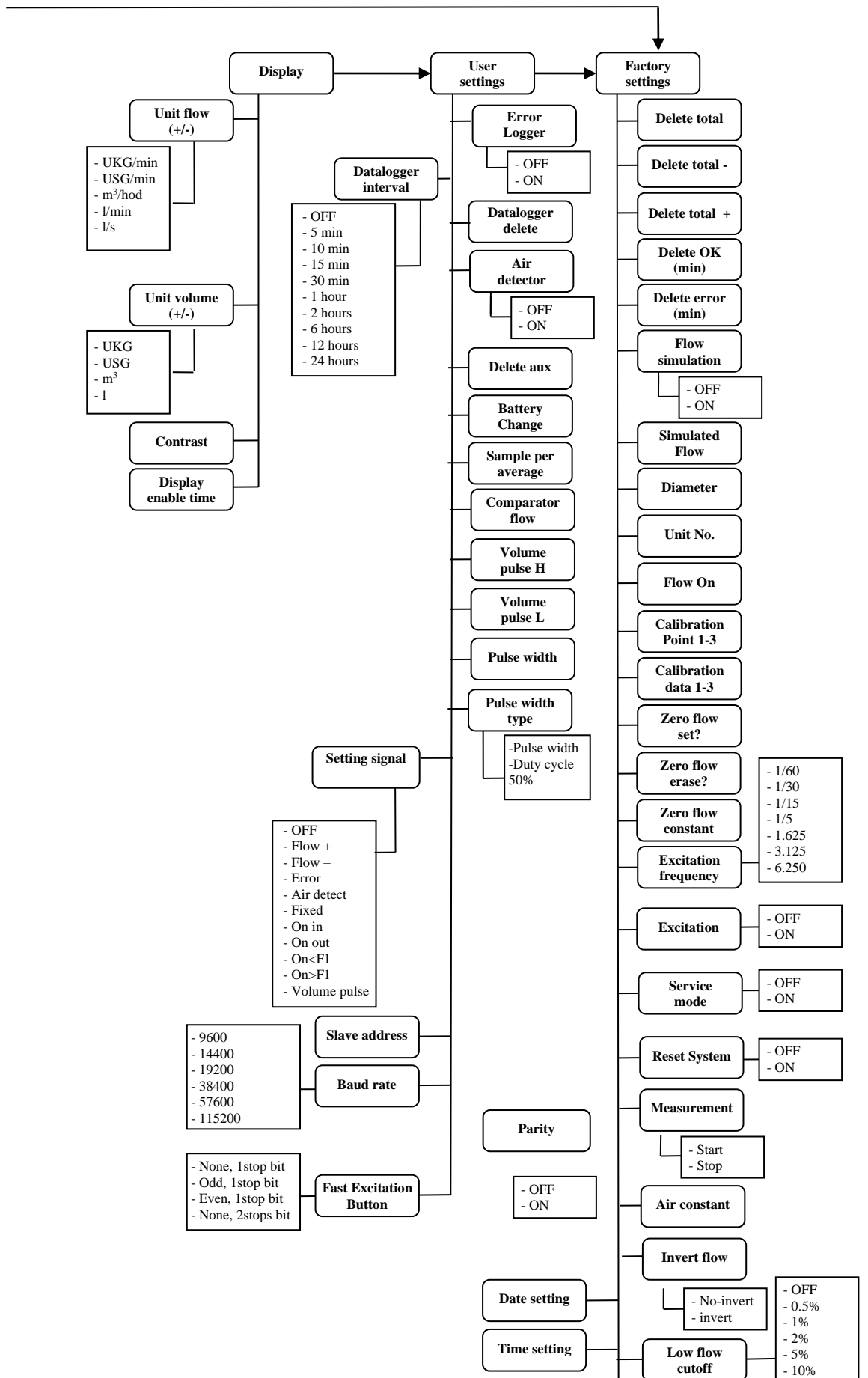

## TABS

- **MENU** - The left-most tab is the "menu" tab, which will display the item selected in the menu-tree on the left hand side of the main window. Some items are only accessible after entering the correct password. When asked for a password, simply enter the correct password for the given section (User and Factory password) and click OK.
- **TIME** - The next tab is "Time". Here, you can enter the correct current time.

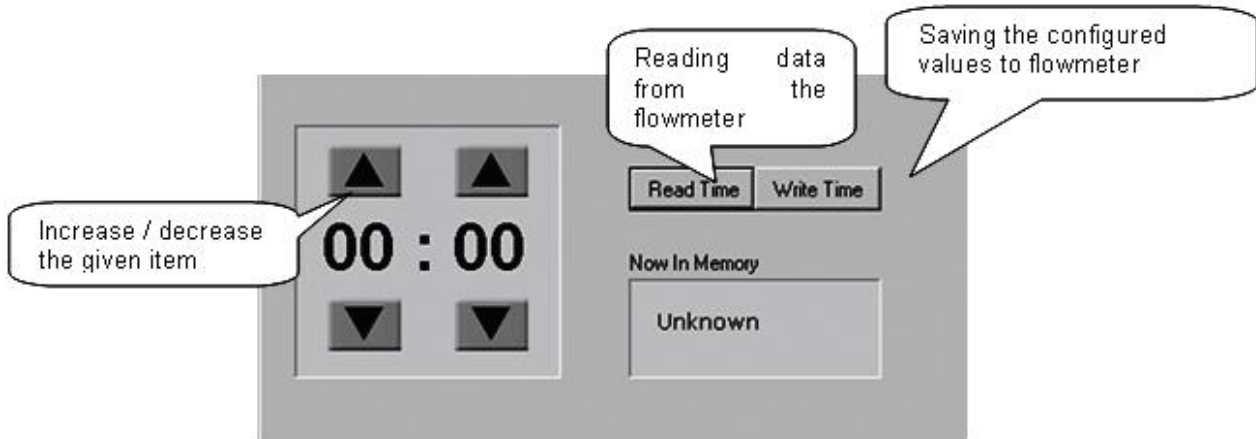

- **DATE** - The third tab from the left is "Date". Here, you can enter the correct current date. (Settings are the same as *TIME* - Tabs)
- **REAL – TIME MEASUREMENT** - The 4<sup>th</sup> tab is "Real-time measurement" and it serves to view actual current flow. The current flow is shown as the first item on top of this window, but it is also depicted in the form of a graph at the bottom. This graph shows current flow data for the last 100 seconds of measurement. On right side are actual errors in red color.

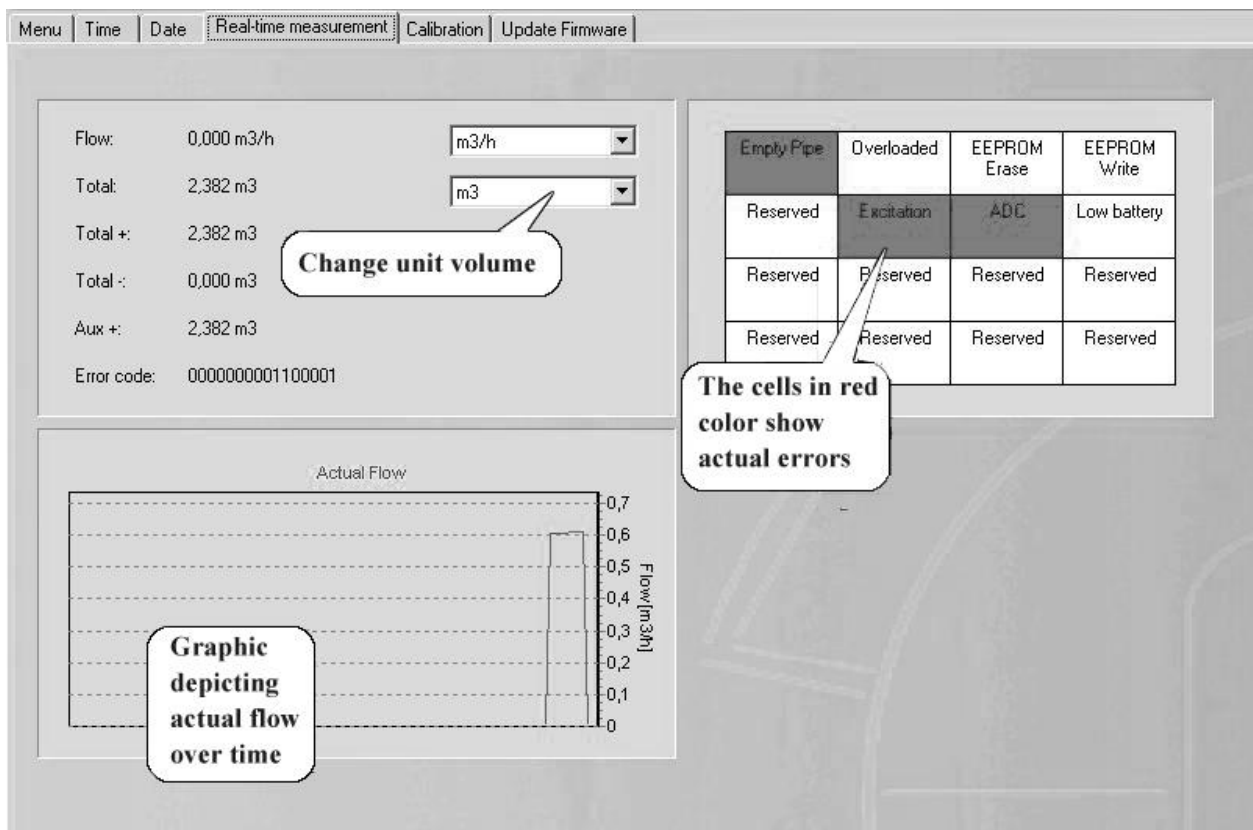



- CALIBRATION** - The next tab is "Calibration", which serves to calibrate the sensor. To enter this sub-menu, you will need the factory password, which in practice means you will never need this section of the manual. You can upload the current sensor calibrations settings, by clicking "Read all".

With the "Write all" button, you can save all currently set calibration values. This button has the same effect as pressing "Write Measurement Data 1", "Write Measurement Data 2", "Write Measurement Data 3" separately.

Using the "Save data file" button, you can save all loaded values. It will not start new data-reading, just the saving of currently loaded data. With the "Open data file" function, you can load calibration values that were saved previously. No values are saved; it will just load/read values for a previously saved file.

During calibration, it is necessary to allocate real flows to the individual values of the measuring sensor ("measurement data"). With the "Write Calibration Data X" button, you allocate the real current flow entered in field 1a (2a, 3a) (above picture) to the current value in the sensor. It is therefore necessary to do any such calibration on an official accredited calibration rig. You can select the flow measurement unit at field number 4 in the above picture.

With the "Write Measurement Data X" button (1b, 2b, 3b) (above picture) you can allocate the flow value under Xa to the sensor value entered in Xb. This option has any use only when correcting an already calibrated sensor. If there is a constant flow error found out in the calibration points while control measuring, it is possible to eliminate this error by edit windows 1c, 2c, 3c. The writing of calibration data must be done by buttons "Write Measurement Data X" in this case.

Calibration point 1 is at the start of the calibration curve, point 2 at the end of the curve, and point 3 in the middle.

Menu | Time | Date | RealTime measurement | **Calibration** | Update Firmware

Calibration data

1a 1,000 Write calibration data 1

2a 11,000 Write calibration data 2

3a 3,000 Write calibration data 3

Write zero flow

Unit: m3/h Reading successfully

Measurement data Error [%]

1b 100 0,00 Write measurement data 1

2b 200 0,00 Write measurement data 2

3b 300 0,00 Write measurement data 3

Calculate measurement point 3

Read all Open data file

Write all Save data file

- UPDATE FIRMWARE – This section update actual Firmware on the flowmeter to other version of firmware. After insert correct factory password choose new firmware in your PC (\*.mgb) and open it.

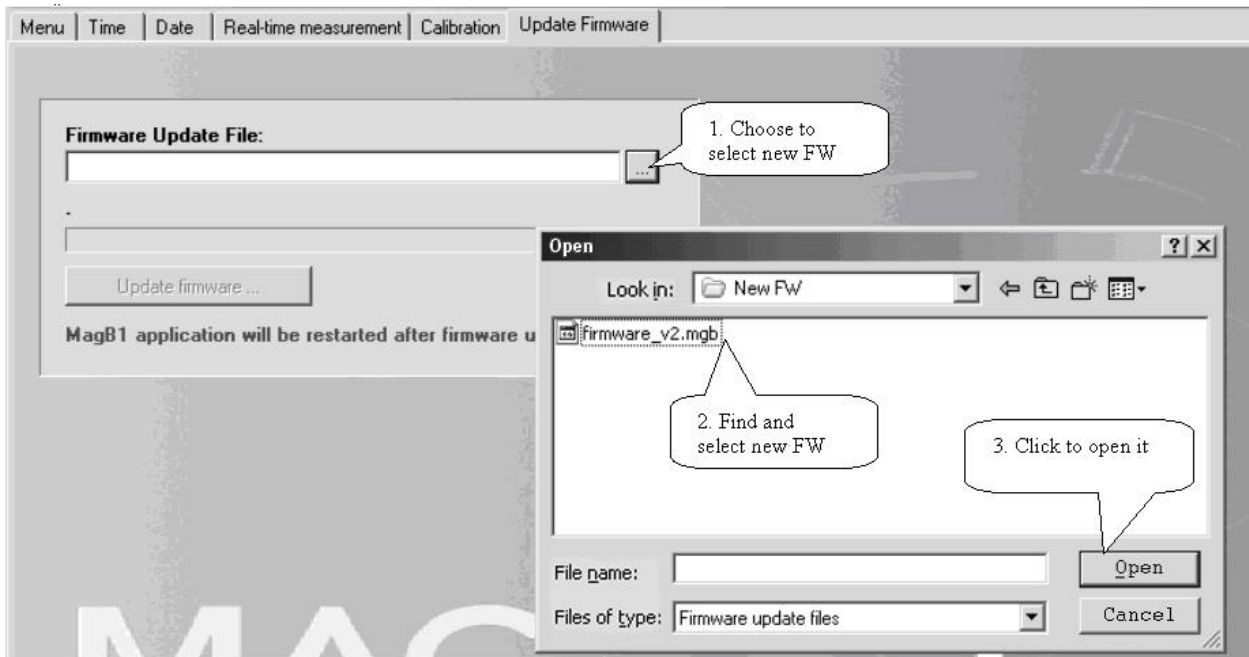

After select and open new FW, click Update firmware button, after this see warning if you really want update firmware. If you accept, click Yes and wait a few seconds while update done. After this MAGB1SW a flowmeter will be restarted. Update successful.

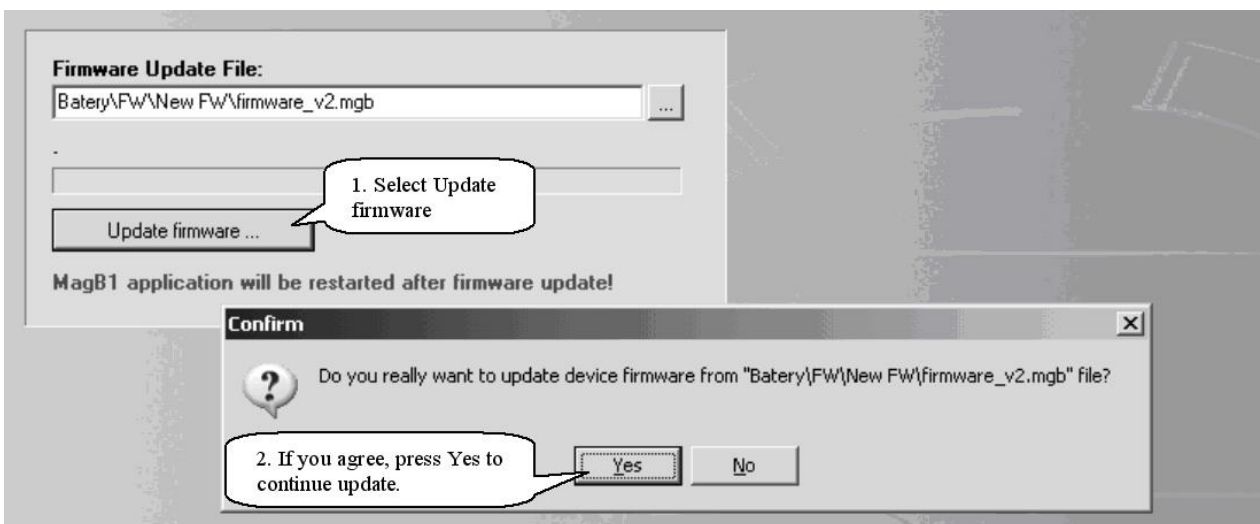

## 12.4. Statistic section

The screenshot displays the 'MAGB1 - Statistika' window. The main area contains a table with the following columns: Date, Time, Total +, Total -, Total, Total + (Volume), Total - (Volume), Total (Volume), and Error code. The data rows show a sequence of timestamps from 22:32:00 to 19:11:00 on 25.10.2010, with corresponding values for each column. The 'Error code' column contains a series of zeros. At the bottom of the window, there are three buttons: 'Load', 'Export', and 'Print'. Three callout boxes provide instructions: 'Read Data from Datalogger' points to the 'Load' button, 'Export Data to \*.csv file' points to the 'Export' button, and 'Print data on your printable' points to the 'Print' button.

Date	Time	Total +	Total -	Total	Total + (Volume)	Total - (Volume)	Total (Volume)	Error code
25.10.2010	22:32:00	0.00	0.00	0.00	-	-	-	0000000000000000
25.10.2010	22:37:00	0.00	0.00	0.00	0.00	0.00	0.00	0000000000000000
25.10.2010	22:42:00	0.00	0.00	0.00	0.00	0.00	0.00	0000000000000000
25.10.2010	22:47:00	0.00	0.00	0.00	0.00	0.00	0.00	0000000000000000
25.10.2010	22:52:00	0.00	0.00	0.00	0.00	0.00	0.00	0000000000000000
25.10.2010	23:01:00	0.02	0.00	0.02	0.02	0.00	0.02	0000000000000000
25.10.2010	16:12:00	0.02	0.00	0.02	0.00	0.00	0.00	0000000000000000
25.10.2010	16:16:00	0.02	0.00	0.02	0.00	0.00	0.00	0000000000000000
25.10.2010	16:21:00	0.02	0.00	0.02	0.00	0.00	0.00	0000000000000000
25.10.2010	16:26:00	0.02	0.00	0.02	0.00	0.00	0.00	0000000000000000
25.10.2010	16:31:00	0.02	0.00	0.02	0.00	0.00	0.00	0000000000000000
25.10.2010	16:36:00	0.02	0.00	0.02	0.00	0.00	0.00	0000000000000000
25.10.2010	16:41:00	0.02	0.00	0.02	0.00	0.00	0.00	0000000000000000
25.10.2010	16:46:00	0.02	0.00	0.02	0.00	0.00	0.00	0000000000000000
25.10.2010	16:51:00	0.02	0.00	0.02	0.00	0.00	0.00	0000000000000000
25.10.2010	16:56:00	0.02	0.00	0.02	0.00	0.00	0.00	0000000000000000
25.10.2010	17:01:00	0.02	0.00	0.02	0.00	0.00	0.00	0000000000000000
25.10.2010	17:06:00	0.02	0.00	0.02	0.00	0.00	0.00	0000000000000000
25.10.2010	17:11:00	0.02	0.00	0.02	0.00	0.00	0.00	0000000000000000
25.10.2010	17:16:00	0.02	0.00	0.02	0.00	0.00	0.00	0000000000000000
25.10.2010	17:21:00	0.02	0.00	0.02	0.00	0.00	0.00	0000000000000000
25.10.2010	17:26:00	0.02	0.00	0.02	0.00	0.00	0.00	0000000000000000
25.10.2010	17:31:00	0.02	0.00	0.02	0.00	0.00	0.00	0000000000000000
25.10.2010	17:36:00	0.02	0.00	0.02	0.00	0.00	0.00	0000000000000000
25.10.2010	17:41:00	0.02	0.00	0.02	0.00	0.00	0.00	0000000000000000
25.10.2010	17:46:00	0.02	0.00	0.02	0.00	0.00	0.00	0000000000000000
25.10.2010	17:51:00	0.02	0.00	0.02	0.00	0.00	0.00	0000000000000000
25.10.2010	17:56:00	0.02	0.00	0.02	0.00	0.00	0.00	0000000000000000
25.10.2010	18:01:00	0.02	0.00	0.02	0.00	0.00	0.00	0000000000000000
25.10.2010	18:06:00	0.02	0.00	0.02	0.00	0.00	0.00	0000000000000000
25.10.2010	18:11:00	0.02	0.00	0.02	0.00	0.00	0.00	0000000000000000
25.10.2010	18:16:00	0.02	0.00	0.02	0.00	0.00	0.00	0000000000000000
25.10.2010	18:21:00	0.02	0.00	0.02	0.00	0.00	0.00	0000000000000000
25.10.2010	18:26:00	0.02	0.00	0.02	0.00	0.00	0.00	0000000000000000
25.10.2010	18:31:00	0.02	0.00	0.02	0.00	0.00	0.00	0000000000000000
25.10.2010	18:36:00	0.02	0.00	0.02	0.00	0.00	0.00	0000000000000000
25.10.2010	18:41:00	0.02	0.00	0.02	0.00	0.00	0.00	0000000000000000
25.10.2010	18:46:00	0.02	0.00	0.02	0.00	0.00	0.00	0000000000000000
25.10.2010	18:51:00	0.02	0.00	0.02	0.00	0.00	0.00	0000000000000000
25.10.2010	18:56:00	0.02	0.00	0.02	0.00	0.00	0.00	0000000000000000
25.10.2010	19:01:00	0.02	0.00	0.02	0.00	0.00	0.00	0000000000000000
25.10.2010	19:06:00	0.02	0.00	0.02	0.00	0.00	0.00	0000000000000000
25.10.2010	19:11:00	0.02	0.00	0.02	0.00	0.00	0.00	0000000000000000

### \*.CSV file

This format file is standard output format for databases. Examples open in Microsoft Excel.

## 13. OIML R49 certification

MAGB1 have been type tested and internationally proven and endorsed to the highest accuracy class 2 for cold and hot potable water meters – OIML R49-1 (Organisation Internationale de Métrologie Légale). For full details, OIML R49 is available to download from [www.oiml.org](http://www.oiml.org). Its requirements are in line with other international standards, such as EN14154 and ISO4064. MAGB1 flowmeter has been evaluated by type approval at the Czech Metrology Institute to OIML R49 and passed the very highest accuracy designations for sizes DN25 to DN150 (1 to 6 in. NB).

The OIML R49-1 certificate of conformity is available on our website ([www.arkon.co.uk](http://www.arkon.co.uk)).

Climatic class: **B**

Electromagnetic class: **E1** for compact, **E2** for remote

Pressure class: **MAP10**

Temperature class: **T50**

Pressure loss: **ΔP 10**

Installation condition: **U5D3**, any installation position

Accuracy class: **2**

Flow direction: **positive**

Q3/Q1 ratio is described in following table:

DN	R	Flow Rate [m3/hr]				R	Flow Rate [m3/hr]				R	Flow Rate [m3/hr]			
		Q1	Q2	Q3	Q4		Q1	Q2	Q3	Q4		Q1	Q2	Q3	Q4
25	50	0,32	0,51	16,00	20,00	100	0,16	0,26	16,00	20,00	160	0,10	0,16	16,00	20,00
32	50	0,50	0,80	25,00	31,25	100	0,25	0,40	25,00	31,25	160	0,16	0,25	25,00	31,25
40	50	0,80	1,28	40,00	50,00	100	0,40	0,64	40,00	50,00	160	0,25	0,40	40,00	50,00
50	50	1,26	2,02	63,00	78,75	100	0,63	1,01	63,00	78,75	160	0,39	0,63	63,00	78,75
65	50	2,00	3,20	100,00	125,00	100	1,00	1,60	100,00	125,00	160	0,63	1,00	100,00	125,00
80	50	3,20	5,12	160,00	200,00	100	1,60	2,56	160,00	200,00	160	1,00	1,60	160,00	200,00
100	50	4,00	6,40	200,00	250,00	100	2,00	3,20	200,00	250,00	160	1,25	2,00	200,00	250,00
125	50	8,00	12,80	400,00	500,00	100	4,00	6,40	400,00	500,00	160	2,50	4,00	400,00	500,00
150	50	12,60	20,16	630,00	787,50	100	6,30	10,08	630,00	787,50	160	3,94	6,30	630,00	787,50
200	50	12,60	20,16	630,00	787,50	100	6,30	10,08	630,00	787,50	160	3,94	6,30	630,00	787,50
250	50	20,00	32,00	1000,00	1250,00	100	10,00	16,00	1000,00	1250,00	160	6,25	10,00	1000,00	1250,00
300	50	32,00	51,20	1600,00	2000,00	100	16,00	25,60	1600,00	2000,00	160	10,00	16,00	1600,00	2000,00

Test report number: 6015-PT-P3014-16







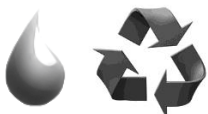

OIML Certificate No.:R49/2013-CZ-16.03

## 14. Liner and electrode selection

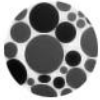

Liner and electrode material selection are an important issue when choosing your flowmeter. The tables below serve to give you an idea of general material compatibility. If you are not sure about suitability of liner/electrode material for a particular medium, please contact the Arkon sales department for further assistance, and the site where the flowmeter is to be used for what materials are acceptable for the process media. Arkon can only recommend materials, we cannot guarantee them.

Please note that Arkon offer also WRAS approved material for all standard sizes. For more info contact our sales department.

Liner Selection:

Hard Rubber	Drinking water and wastewater		 0 - 70°C
Soft Rubber	Water with abrasive particles		 0 - 70°C
PTFE	Chemicals and food industries		 0 - 130°C
Hygienic Rubber	Drinking water, WRAS approved		 cold water

Electrode selection:

Hastelloy	General purpose, sewage, water, seawater, chemicals	
Titanium	Aggressive chemicals	
Platinum	Aggressive chemicals	

# 15. Flowmeter Dimensions

## Compact version

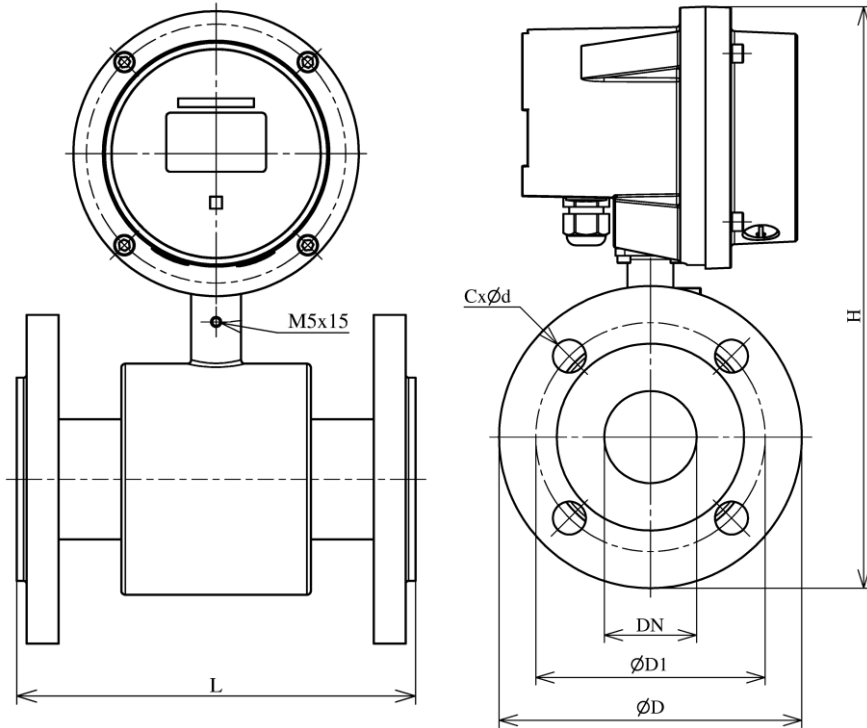

## Remote version

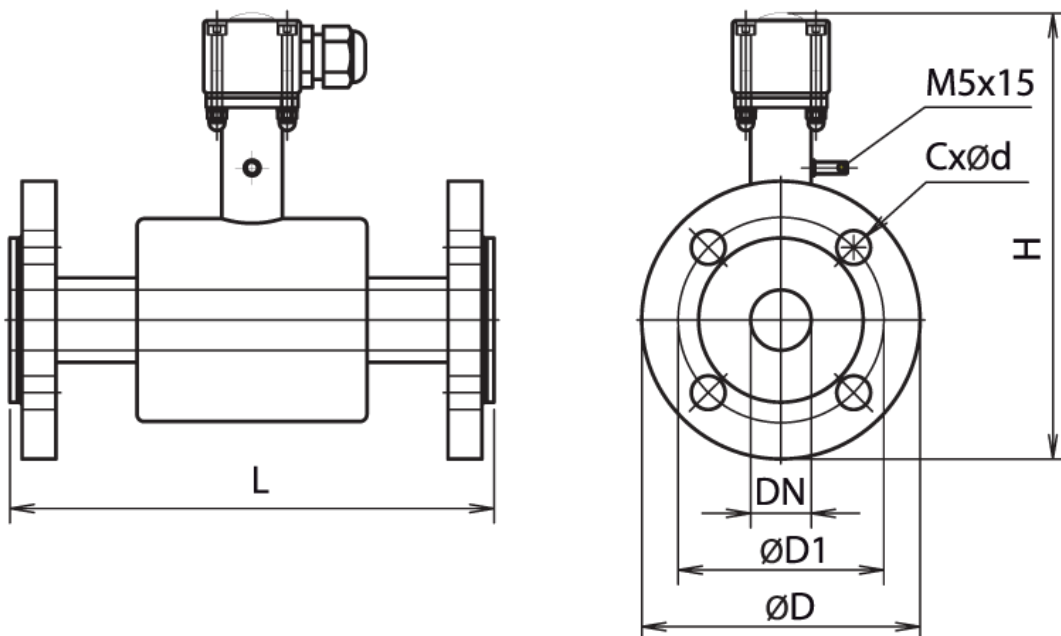

DN	ØD	ØD1	CxØd	H_compact	H_remote	L
10	90	60	4x14	257	160	200
15	95	65	4x14	262	165	200
20	105	75	4x14	269	172	200
25	115	85	4x14	275	178	200
32	140	100	4x18	293	196	200
40	150	110	4x18	302	205	200
50	165	125	4x18	316	219	200
65	185	145	8x18	336	239	200
80	200	160	8x18	354	257	200
100	220	180	8x18	374	277	250
125	250	210	8x18	407	310	250
150	285	240	8x22	440	343	300
200	340	295	12x22	496	399	350
250	405	355	12x26	566	469	400
300	460	410	12x26	615	518	500
350	520	470	16x26	683	586	500

DN	ØD	ØD1	CxØd	H_compact	H_remote	L
1/2"	88.9	60.5	4x15,7	258	161	200
3/4"	98.6	69.9	4x15,7	266	169	200
1"	108	79.2	4x15,7	271	174	200
1.1/4"	117.3	88.9	4x15,7	282	185	200
1.1/2"	127	98.6	4x15,7	290	193	200
2"	152.4	120.7	4x19,1	309	212	200
2.1/2"	177.8	139.7	4x19,1	332	235	200
3"	190.5	152.4	4x19,1	349	252	200
4"	228.6	190.5	8x19,1	378	281	250
5"	254	215.9	8x22,4	409	312	250
6"	279.4	241.3	8x22,4	437	340	300
8"	342.9	298.5	8x22,4	497	400	350
10"	406.4	362	12x25,4	566	469	400
12"	482.6	431.8	12x25,4	626	529	500
14"	533.4	476.3	12x28,4	690	593	500

Tolerance of built-in length and height for DIN and ANSI type sensors:

DN 10 – DN 150 → L ± 5 mm

DN 200 – DN 1000 → L ± 10 mm

Standard pressure:

DN 10 – DN 50 → PN 40 / 150 lbs.

>DN 50 → PN 16 / 150 lbs.

## 16. How to order your MAGB1

In case you are interested in purchasing a MAGB1 flowmeter, you can either contact the Arkon Sales Department and request a quote to serve as a basis for ordering, or you can use the Arkon price-list as an easy order form. Due to the design of the MAGB1, no single ordering code exists. Only the MAGB1 sensor has its own ordering code:

Model	Ordering code							Description
MAGB1 IP68								Standard calibration
MAGB1 IP68 OIML	1	2	3	4	5	6	7	OIML R49 Version
MAGB1 IP68 MID								MID Version -MI-001, Class 2
								<b>Version</b>
C								Compact
W								Remote: WALL mounting kit (including 6m cable)
P								Remote: PANEL mounting kit (including 6m cable)
R								Remote: DIN-Rail mounting kit (including 6m cable)
								<b>Connection type</b>
D								DIN
A								ANSI
								<b>Size</b>
		20 / 3/4						20mm / 3/4"
		25 / 1						25mm / 1"
		32 / 1.1/4						32mm / 1.1/4"
		40 / 1.1/2						40mm / 1.1/2"
		50 / 2						50mm / 2"
		65 / 2.1/2						65mm / 2.1/2"
		80 / 3						80mm / 3"
		100 / 4						100 mm / 4"
		125 / 5						125 mm / 5"
		150 / 6						150 mm / 6"
		200 / 8						200 mm / 8"
		250 / 10						250 mm / 10"
								<b>Liner material</b>
				HR				Hard Rubber
				SR				Soft Rubber
				PT				PTFE
				NR				Hygienic rubber
								<b>Pressure</b>
					150			150 psi
					300			300 psi
					10			PN10
					16			PN16
					25			PN25
					40			PN40
								<b>Electrodes material</b>
						HA		Hastelloy C
						TA		Tantalum
						TI		Titanium
						PL		Platinum
								<b>Communication</b>
						GPRS		3G/GPRS/GSM
						485		RS485

Example

MAGB1 IP68	C	D	100	HR	16	HA
------------	---	---	-----	----	----	----

Example OIML, IP68 unit

MAGB1 IP68 OIML	C	D	100	HR	16	HA
-----------------	---	---	-----	----	----	----



## 17. MAGB1 Error Code Table

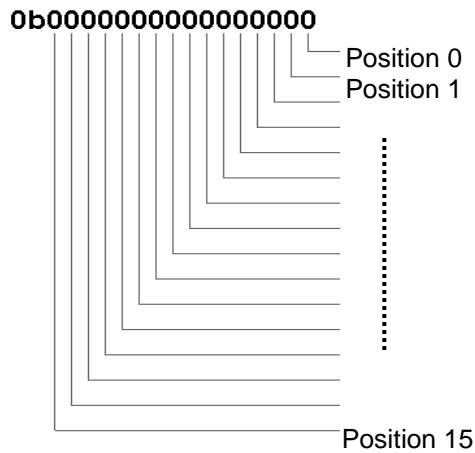

MAGB1 can detect and show a number of errors in one error code value.

Error position	Error Description
0	Empty Pipe (Air Detect)
1	Overloaded
2	EEPROM Erase
3	EEPROM Write
4	Excitation
5	AD converter error
6	Low Battery
7	Overload flow
8-15	RESERVED (non-use)



**Errors on the display are indicated in hex format. This number must be converted to binary format! You can use a calculator with hex converting function.**

Once the error code has been converted to binary format, each position is related to a different error (see the table above). Number 1 indicates error and number 0 indicates no error.

Example:

Error shown on display:	Error position:	Readed errors:
	76543210	
043HEX =	01000011 BIN	Low battery / Overloaded / Empty pipe

## 18. Firmware version compatibility

It is possible to check the version of each MAGB1 in info menu > Firmware No.  
MAGB1 offers the option of updating the firmware version using USB connection.

FW	MB		RS485	SMS	Power Supply
10.28	v5.1		no	no	battery
10.30	v5.1	couple versions customized	no	yes	battery
10.31	v5.1		yes	no	battery

## 19. Appendix

### 19.1. CE and Conformity

The MAGB1 Electromagnetic flowmeter is manufactured conform CE requirements.



### 19.2. Warranty

The warranty conditions are covered by Arkon Flow Systems, s.r.o. Terms & Conditions of Sale and by Arkon Flow Systems, s.r.o Return Regulations and Warranty Conditions. The Arkon Flow Systems, s.r.o Terms & Conditions of Sale and the Arkon Flow Systems, s.r.o Return Regulations and Warranty Conditions are an integral part of the Resellers contract and of any Order Confirmation. Please see your Resellers contract or [www.arkon.co.uk](http://www.arkon.co.uk); Support section. The Warranty sheet is part of the Packing note of any new goods sent. For the claim or return procedure, please consult our web site [www.arkon.co.uk](http://www.arkon.co.uk) or call the Arkon Flow Systems, s.r.o. sales office.

### 19.3. Contact



Technical support: [support@arkon.co.uk](mailto:support@arkon.co.uk)  
Skype: support.arkon

Sales office: [arkon@arkon.co.uk](mailto:arkon@arkon.co.uk)

Office hours:  
8:30 – 18:00 (GMT+1)

Direct technical support:  
8:00 – 17:00 (GMT+1)