

General

CRF-300 is a fully automatic flow meter based on microwave technology. It uses advanced K-band planar radar technology to measure the flow velocity and water level of the water body in a non-contact manner. According to the built-in software model and algorithm, it calculates and outputs real-time instantaneous flow and cumulative flow at a cross-section. It can be used for non-contact flow measurement in rivers, irrigation canals, underground drainage pipe networks, flood control early warning and other occasions.

It has the characteristics of low power consumption, high reliability, and convenience; the measurement process is not affected by temperature, sediment, pollutants, and floating objects on the water surface.



CRF300(Standard Version)



CRF300-R(RTU Version)

Features

- Adopt non-contact measurement, combined with cross-section parameters to calculate the flow rate, not affected by wind, temperature, haze, sediment, floating objects, etc. With a rainproof mode;
- Suitable for a variety of measurement conditions, and measurement data of velocity, water level, and flow rate can be output;
- Expandable array type multi-point flow measurement, by configuring a set of flow meters and multiple sets of velocity meters, the flow measurement of a wide section can be realized;
- Applicable to multiple cross-sections such as trapezoid, round, U-shaped, etc.; the parameter setting method of the cross-section is simple and convenient;
- Software can be configured, the parameters can be configured according to actual needs to adapt to different conditions of use.

Applications

Velocity/ water level/flow measurement of rivers, lakes, tides, reservoir gates, ecological discharge flow, underground pipe networks, irrigation canals, etc.

Auxiliary water treatment, such as urban water supply, sewage monitoring, etc.

Flow calculation, water inlet and drainage flow monitoring, etc.

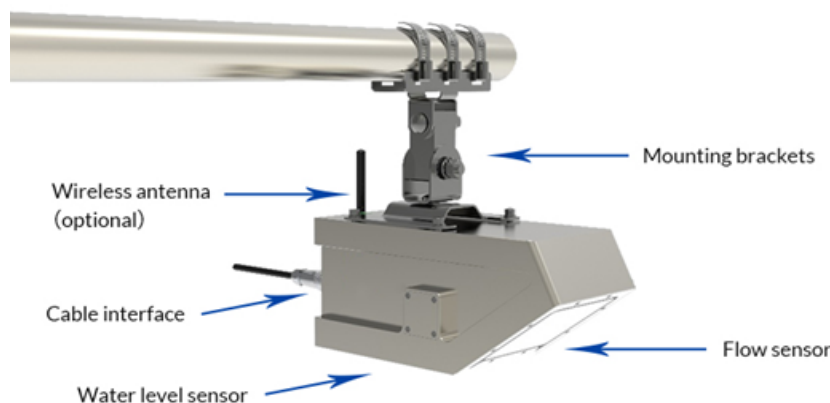

Dimensions Unit, mm

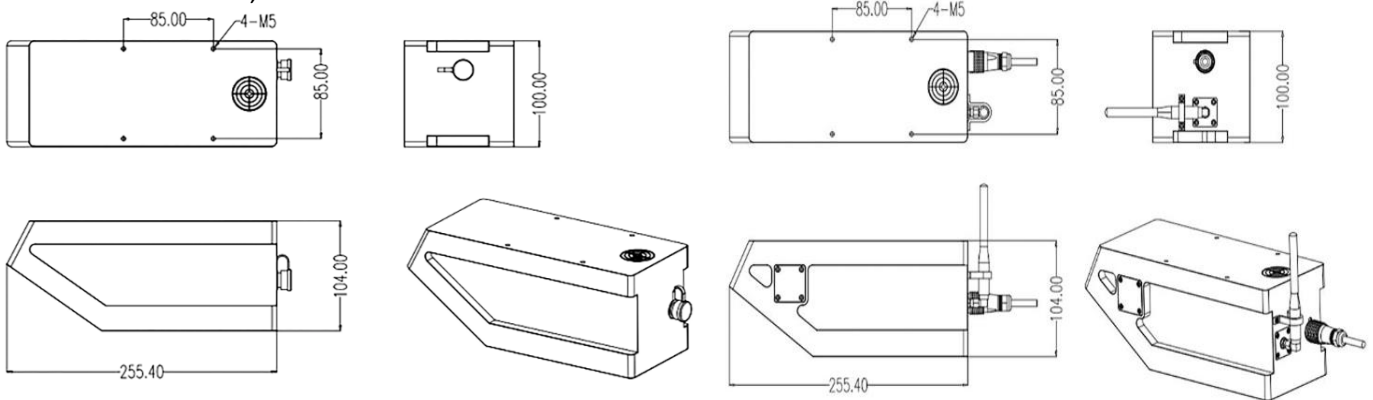

CRF300 Dimension

CRF300-R Dimension

Specifications

Item	CRF300/CRF300-R
Version	CRF300(Standard version) CRF300-R(RTU version) Support parameter adjustment by Bluetooth; wireless configuration and maintenance by mobile phone; equipment remote upgrade

Velocity Measurement System

Measuring Principle	Planar microstrip array antenna CW+FMCW
Operating Mode	Manual, automatic, telemetry
Applicable environment	24-hour, rainy days
Operating temperature	-35~70 C
Operating Voltage	7~32VDC,5.5-32VDC(assorting)
Working current	12VDC input, working mode: ≤35mA standby mode: ≤1mA IP Rating IP68
Lightning protection level	6KV

Radar Wave Velocity Meter

Radar frequency	24GHz
Max measuring range	40m
Velocity range	0.03~20m/s
Velocity measurement acc	±0.01m/s;±2%FS
Antenna angle	12°
Measuring direction	Automatic recognition of water flow direction, built-in vertical angle correction

Radar Water Level Sensor

Radar frequency	80Ghz
Measuring range	40 meters
Measurement accuracy	±2mm,±0.05%FS
Antenna angle	8°

Data transmission system

Data transmission	RS485 / RS232, 4~20mA, LoRa (wireless option), NB-IoT
-------------------	---